

Available in online @ [www.iaraindia.com](http://www.iaraindia.com)

SCIENCE EXPLORE-An International Journal on Science and Knowledge in General

ISSN: 3139-2997 (Online)

Volume I, Issue 1

January – June 2026

## FLOOD ACTIONS AND STRUCTURAL RESPONSE OF A G+4 REINFORCED CONCRETE BUILDING IN SPECIAL FLOOD HAZARD AREAS

**RISHAV SINGH**

Assistant Professor

Dream Institute of Technology

**RAKESH SEN**

Student

Dream Institute of Technology

### ABSTRACT

*Flood damage assessment for buildings is commonly based on depth–damage relationships, which often fail to represent the complex physical mechanisms governing structural failure during extreme flood events. This paper presents a flood-action-based analytical framework to evaluate the structural performance of a multi-storey reinforced concrete (RC) building subjected to extreme flooding. Flood actions are defined as the direct mechanical effects exerted by floodwaters on a structure, including hydrostatic pressure, hydrodynamic drag, buoyancy, and debris impact. A G+4 RC residential building was modeled and analyzed using SAP2000 under conventional design loads and combined flood-induced loading scenarios representative of Special Flood Hazard Areas (SFHAs). The results reveal that flood actions generate lateral forces and bending moments significantly exceeding those produced by wind loading. Critical failures were observed in ground-floor columns and beams due to excessive axial forces and flexural demands. To mitigate these failures, structural modifications were proposed, including increasing column dimensions to 650 × 650 mm, upgrading concrete strength from M25 to M30, and enhancing reinforcement ratios to improve ductility. The redesigned structure demonstrated satisfactory performance under identical flood loading conditions. The study highlights the importance of explicitly incorporating flood actions into structural design practice for buildings located in flood-prone regions.*

**KEYWORDS** Flood actions · Hydrodynamic load · Hydrostatic pressure · Debris impact · Reinforced concrete · SAP2000

### INTRODUCTION

Flooding is among the most severe natural hazards affecting the built environment, particularly in developing countries where infrastructure growth often exceeds resilience planning. In India, recurring floods in states such as Assam, Bihar, West Bengal, Andhra Pradesh, and Odisha have resulted in extensive economic losses and large-scale housing damage. According to national flood assessments, nearly 40 million hectares of land are vulnerable to flooding, with residential structures constituting a significant portion of the exposed assets.

Structural damage during floods is not governed solely by water depth. Instead, it arises from complex interactions between flowing water, foundation soil, and structural

materials. Saturated soils exhibit reduced bearing capacity, while flowing water induces lateral drag forces and foundation scouring. In certain regions, flooding coinciding with seismic activity can further induce soil liquefaction, intensifying structural distress.

Conventional flood damage models primarily emphasize slow-rise inundation depth and often neglect dynamic effects such as flow velocity and debris impact. This limitation motivates the adoption of a flood-action-based framework, wherein the physical actions exerted by floodwaters are explicitly quantified and applied in structural analysis.

## LITERATURE REVIEW

### Flood Action-Based Damage Assessment

Recent research advocates transitioning from depth-based flood damage models to approaches that explicitly consider flood actions. Kelman and Spence demonstrated that hydrostatic, hydrodynamic, and impact forces play a decisive role in determining structural damage and failure mechanisms. Depth-only models frequently underestimate damage, particularly in high-velocity flood scenarios.

### Hydrodynamic and Impact Effects

Experimental and numerical investigations have shown that flood-induced pressures vary with flow velocity, depth, and building geometry. Nadal et al. reported that hydrodynamic forces can amplify structural damage by more than 100% compared to hydrostatic loading alone. Impact pressures are typically concentrated near the base of structures, decreasing with height, while lateral pressure distributions are influenced by boundary effects.

### Material Degradation and Soil–Structure Interaction

Flooding significantly alters the mechanical properties of construction materials and foundation soils. Soil saturation reduces stiffness and shear strength, leading to settlement and scouring. Masonry and mortar experience degradation of bond strength under prolonged wetting, while reinforced concrete members exhibit increased vulnerability due to combined axial and bending stresses. Studies indicate that partially saturated conditions may be more detrimental than full saturation in terms of compressive strength reduction.

### Research Gap

Although extensive literature exists on flood impacts on low-rise and masonry buildings, limited studies address the response of multi-storey RC framed structures subjected to combined flood actions using advanced finite element analysis. This study aims to bridge this gap.

## OBJECTIVES AND METHODOLOGY

### Objectives

The objectives of this study are:

- To model a G+4 reinforced concrete framed building using finite element techniques.
- To evaluate structural response under combined flood actions.
- To identify critical members susceptible to flood-induced failure.
- To propose and validate design modifications for enhanced flood resilience.

### Methodology

The methodology adopted in this study follows a structured analytical framework to investigate the response of a reinforced concrete building subjected to extreme flood-induced actions. A G+4 reinforced concrete framed residential structure was first modeled and designed in accordance with the provisions of IS 456:2000 using the limit state design approach. To establish baseline structural performance, the model was subjected to conventional gravity and lateral loads, including dead loads, live loads, and wind loads as specified in IS 875, along with seismic loading considerations in compliance with IS 1893.

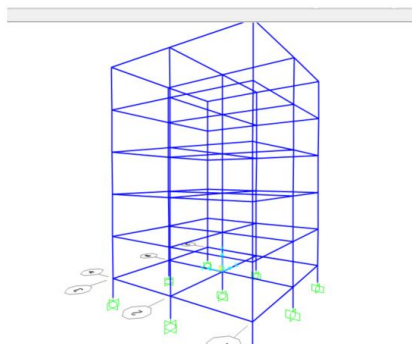

Fig: Showing all members after redesign

Subsequently, flood-related actions were incorporated into the analytical model by simulating lateral hydrostatic pressure, hydrodynamic drag forces, buoyancy effects, and debris impact loads, computed following internationally accepted ASCE and USACE guidelines.

A comparative assessment was then carried out to evaluate variations in internal forces, joint displacements, bending moments, shear forces, and base reactions under standard and flood loading conditions. Based on the identified overstressed and failed structural members, design modifications were introduced through revisions in cross-sectional dimensions, material grades, and reinforcement detailing. The modified structural model was finally reanalyzed to assess the effectiveness of the proposed design enhancements in improving the overall flood resilience of the structure.

**STRUCTURAL CONFIGURATION AND MATERIAL PROPERTIES**

**Building Description**

The analyzed structure is a G+4 residential RC framed building with plan dimensions of 16 m × 12 m and a uniform storey height of 3.2 m. The structural system consists of moment-resisting frames with monolithic slab–beam–column connections.

**Material Properties**

Parameter	Original Design	Modified Design
Concrete grade	M25	M30
Reinforcement	Fe 415	Fe 415 (enhanced ratio)
Ground-floor column size	450 × 450 mm	650 × 650 mm

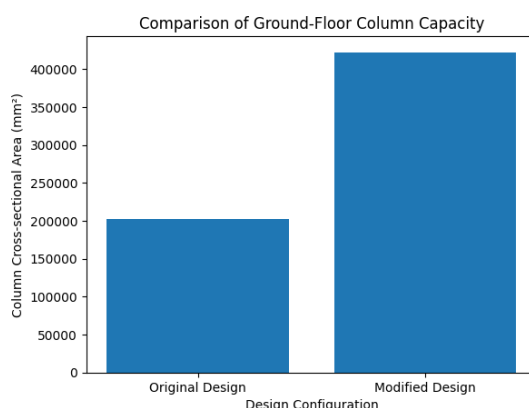

**Chart: Comparison of Ground-Floor Column Capacity**

From above Figure presents a comparative bar chart illustrating the increase in ground-floor column cross-sectional area between the original and modified structural designs. The original design employed columns of size 450 × 450 mm, whereas the redesigned configuration adopted enlarged columns of 650 × 650 mm to improve flood resistance.

The comparative chart highlights a substantial increase in the load-carrying capacity of the ground-floor columns following the proposed structural modifications. In the original design,

the column cross-sectional area was 202,500 mm<sup>2</sup>, which proved inadequate to resist the elevated axial forces and bending moments induced by combined hydrostatic, hydrodynamic, and debris impact loads during flood conditions. In contrast, the modified design increased the column size to 650 × 650 mm, resulting in a cross-sectional area of 422,500 mm<sup>2</sup>—more than a 100% increase compared to the original configuration. This geometric enhancement significantly improves stress distribution, reduces demand-to-capacity ratios, and enhances overall structural stiffness at the base level, where flood-induced forces are most critical. When combined with the upgrade in concrete grade from M25 to M30 and an increased reinforcement ratio using Fe 415 steel, the redesigned columns exhibit improved strength, durability, and ductility, thereby ensuring a resilient structural response under extreme flood loading scenarios.

**FLOOD LOAD CHARACTERIZATION**

**Flood Parameters**

Flood loading was defined based on representative extreme flood conditions:

- Flood depth: 3.2 m
- Flow velocity: 2.25 m/s
- Unit weight of water: 9.81 kN/m<sup>3</sup>

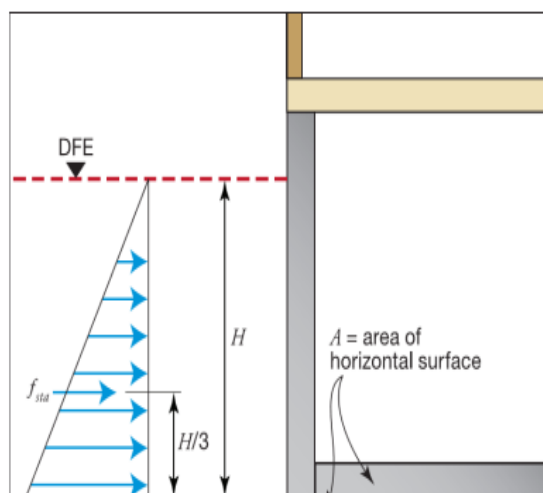

Fig: Hydrostatic load on building

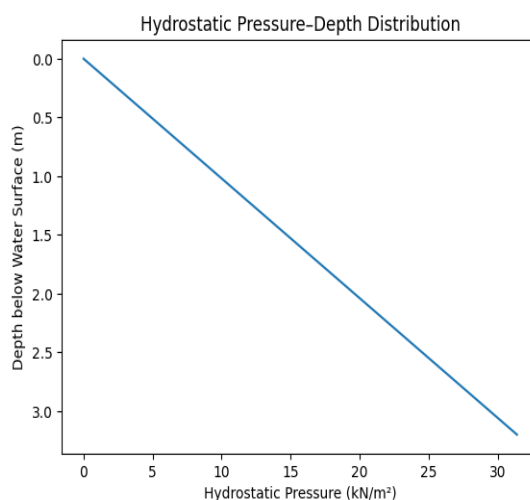

Fig. 6 Hydrostatic pressure–depth distribution showing the triangular variation of pressure with increasing flood depth

The pressure–depth distribution graph illustrates the variation of hydrostatic pressure with increasing water depth along the submerged height of the structure. As shown in Fig. 6, hydrostatic pressure increases linearly with depth due to the self-weight of water, resulting in a triangular pressure profile acting on the vertical face of the building. At the water surface, the pressure is zero, while the maximum pressure occurs at the base of the flood depth (3.2 m). This triangular distribution produces a resultant lateral force acting at one-third of the flood depth measured from the base, which significantly contributes to bending moments and shear forces in ground-floor columns and beams. The concentration of maximum pressure near the base explains the observed failure patterns in lower-story structural members under flood loading conditions.



Fig: Hydrodynamic and impact forces

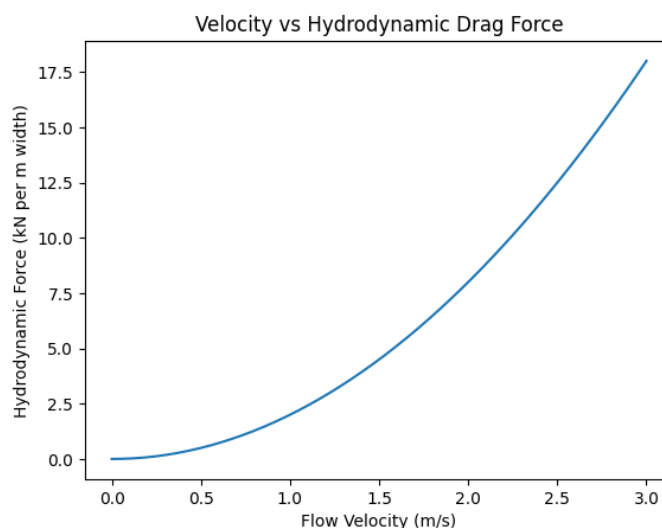

Fig. 7 Relationship between floodwater velocity and hydrodynamic drag force acting on the structure.

Figure 7 presents the relationship between flow velocity and the resulting hydrodynamic drag force acting on the structure. The graph demonstrates a nonlinear, quadratic increase in hydrodynamic force with increasing flow velocity, as the drag force is proportional to the square of the velocity. Even moderate increases in floodwater velocity result in a disproportionately large rise in lateral force demand on the building façade. At

higher velocities, the hydrodynamic force becomes comparable to or greater than hydrostatic forces, significantly amplifying bending moments and axial stresses in structural members. This behavior highlights the critical importance of incorporating velocity-dependent hydrodynamic effects in flood-resistant structural design, particularly for buildings located in Special Flood Hazard Areas.

**Flood Actions Considered**

Flood action	Description
Hydrostatic pressure	Depth-dependent lateral pressure
Hydrodynamic drag	Velocity-induced lateral force
Debris impact	Concentrated horizontal impact load

**RESULTS AND DISCUSSION**

**Joint Displacements**

Flood loading resulted in substantial lateral displacements, particularly at upstream façade joints.

Joint	U <sub>1</sub> (m)	U <sub>2</sub> (m)	U <sub>3</sub> (m)
6	0.0129	0.0179	-0.00017
18	0.0129	0.0179	-0.00115
30	0.0129	0.0179	-0.00370
54	0.0129	0.0179	-0.00213

Flood loading induced significant lateral displacements, particularly at joints located along the upstream façade of the structure. The horizontal displacement components U<sub>1</sub> and U<sub>2</sub> remained nearly constant across the selected joints, with maximum values of approximately 0.0129 m and 0.0179 m, respectively, indicating a dominant global sway response under lateral flood forces. The higher magnitude of U<sub>2</sub> confirms that the principal flood flow direction governs the structural deformation. In contrast, vertical displacements (U<sub>3</sub>) were relatively small but increased with elevation, reaching a maximum downward value of -0.00370 m. This behavior reflects the combined influence of axial force variation and bending effects in columns subjected to flood-induced lateral loading.

**Bending Moments in Critical Members**

Ground-floor columns experienced severe flexural demands, with maximum bending moments exceeding 4,000 kN·m.

Frame	Station (m)	M <sub>3</sub> (kN·m)
119	0	3926.6
123	0	3910.6
125	0	4094.8
129	0	4095.0

The bending moment results indicate that ground-floor columns are subjected to severe flexural demands under flood loading conditions. As summarized in Table X, maximum bending moments at the base level (Station 0 m) exceed 4,000 kN·m in several critical columns. Frames 125 and 129 exhibit the highest bending moments, reaching approximately 4095 kN·m, while Frames 119 and 123 also experience values close to this range. These elevated flexural demands are primarily attributed to the combined effects of hydrostatic pressure, hydrodynamic drag, and debris impact forces acting near the base of the structure. The concentration of high bending moments at ground-floor columns explains the observed failure patterns and highlights the necessity for enhanced section capacity and material strength in flood-prone regions.

**Base Reactions**

Flood actions generated high lateral shear demands at the foundation level, indicating the need for enhanced foundation and column design in SFHAs.

## FAILURE ASSESSMENT AND STRUCTURAL REDESIGN

Finite element analysis revealed failure of several ground-floor columns and beams due to combined axial and flexural overstressing. To address this, column cross-sections were enlarged, concrete strength was increased, and reinforcement ratios were enhanced to improve ductility and energy dissipation capacity. Reanalysis confirmed that the modified structure remained within permissible stress limits under flood loading.

## CONCLUSIONS

This study demonstrates that multi-storey RC buildings designed using conventional load combinations are highly susceptible to extreme flood events.

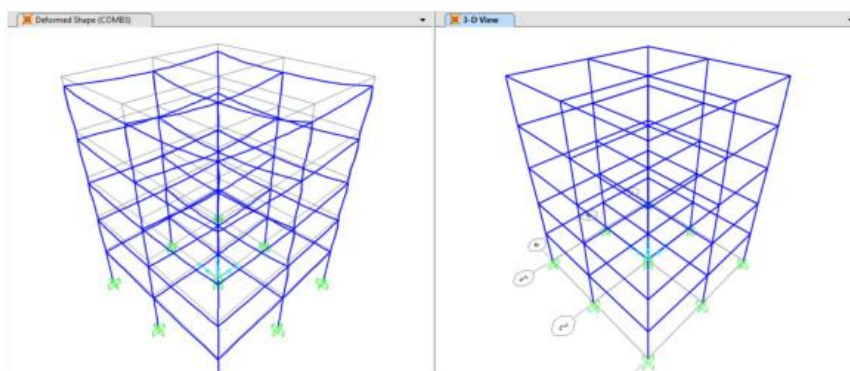

Fig: Displacement of the joints

Flood actions impose lateral demands far exceeding those generated by wind loads, leading to critical failures in lower-storey members. Incorporating flood-specific actions into structural analysis and adopting enhanced design measures—such as increased column dimensions and higher concrete grades—significantly improves flood resilience. The proposed framework provides a practical basis for flood-resilient design of reinforced concrete buildings in Special Flood Hazard Areas.

## REFERENCES

1. Alvarado JM (2011) The effects of moisture content on soil strength. California State Science Fair, Sacramento
2. ASCE (2014) Flood resistant design and construction (ASCE/SEI 24-14). American Society of Civil Engineers, Reston
3. ASCE (2017) Minimum design loads and associated criteria for buildings and other structures (ASCE/SEI 7-16). American Society of Civil Engineers, Reston
4. BIS (2000) IS 456: Plain and reinforced concrete – code of practice. Bureau of Indian Standards, New Delhi
5. BIS (2015) IS 875 (Part 3): Design loads (other than earthquake) for buildings and structures – wind loads. Bureau of Indian Standards, New Delhi
6. BIS (2016) IS 1893 (Part 1): Criteria for earthquake resistant design of structures. Bureau of Indian Standards, New Delhi
7. Clausen L, Kok M, Beersma J (1990) Linear correlations between flood velocity and damage parameters. *Hydrol Sci J* 35(1):45–58
8. FEMA (2015) Flood damage-resistant materials requirements. FEMA Technical Bulletin 2, Washington DC
9. Franzoni E, Gentilini C, Graziani G, Bandini S (2015) Compressive behaviour of brick masonry triplets in wet and dry conditions. *Constr Build Mater* 94:269–279
10. Groot CJWP (1993) Effects of water on mortar–brick bond. PhD Thesis, Delft University of Technology
11. Kelman I, Spence R (2004) An overview of flood actions on buildings. *Eng Geol* 73(3–4):297–309

12. Kemper WD, Rosenau RC (1984) Soil cohesion as affected by time and water content. *Soil Sci Soc Am J* 48(5):1001–1006
13. Kreibich H, Thielen AH (2009) Flood damage assessment and the influence of hydraulic characteristics. *Nat Hazards Earth Syst Sci* 9:1679–1695
14. Medero GM, Kennedy JH, Woodward PK, Banimahd M (2010) Flooding effects on earth walls. *Proc ICE Constr Mater* 163(3):153–163
15. Nadal NC, Zapata RE, Pagán I, López R, Agudelo J (2010) Building damage due to riverine and coastal floods. *J Water Resour Plan Manag* 136(3):327–336
16. NFIP (2019) Special flood hazard areas and floodplain management guidelines. National Flood Insurance Program, USA
17. Roos IW (2003) Damage to buildings by flooding. Delft Cluster Report, Delft
18. Saatcioglu M, Ghobarah A (2002) Impact of flooding on reinforced concrete structures. *Struct Eng Int* 12(4):283–289
19. Sap2000 (2022) Integrated structural analysis and design software—user manual. Computers and Structures Inc., Berkeley
20. Smith DI (1994) Flood damage estimation—A review of urban stage-damage curves and loss functions. *Water SA* 20(3):231–238
21. USACE (2012) Coastal engineering manual. US Army Corps of Engineers, Washington DC
22. Xiao S, Li H (2013) Impact of flood on a simple masonry building. *J Perform Constr Facil* 27(2):211–220
23. Xiao S, Yue B, Wang X, Yang L (2014) Experimental study on impact loading of flood on buildings. *J Hydraul Eng* 140(4):04014005
24. Yin J, Yu D, Yin Z, Wang J, Xu S (2016) Modelling the impact of flood hazards on residential buildings. *Nat Hazards* 81(1):135–151
25. Zhai G, Ikeda S (2008) Flood risk analysis and damage evaluation in urban areas. *Int J Disaster Risk Sci* 1(1):1–12