

Available online @ [www.iaraindia.com](http://www.iaraindia.com)  
RESEARCH EXPLORER-A Blind Review & Refereed Quarterly International Journal  
ISSN: 2250-1940 (P) 2349-1647 (O)  
Impact Factor: 3.655 (CIF), 2.78 (IRJIF), 2.62 (NAAS)  
Volume X, Issue 35  
April-June 2022  
Formally UGC Approved Journal (63185), © Author

## EXPLORING THE CRITICAL EFFECT OF FINANCIAL LITERACY ON SUSTAINABLE BUSINESS PERFORMANCE IN THE CONTEXT OF FIRM PERFORMANCE OF SMES IN SRI LANKA

ATHAMBAWA HALEEM

Senior Lecturer  
Department of Accountancy and Finance  
Faculty of Management and Commerce  
South eastern university of Sri Lanka  
[ahaleem@seu.a.lk](mailto:ahaleem@seu.a.lk)

### ABSTRACT

*A new way of doing business has gained widespread attention since Sustainable business performance is crucial for organization and society, and business organization has always focused to attain firm performance. Hence, to increase firm performance and attain sustainable firm performance, Financial Literacy (FL) is an important factor to understand and manage the financial resources of small and medium-sized enterprises (SMEs). The core purpose of this study is to measure the nexus between FL and sustainable business performance through mediating effect of firm performance, and the moderating effect of business types. The theory of Resource-Based View (RBV) was applied to form a conceptual model. A sample of 260 SMEs was obtained from the Eastern Province of Sri Lanka. A structured questionnaire was developed to collect data. The analysis was done using a structural equation model (SEM) to test the hypothesis. The findings proved that a significant relationship exists among the three dimensions of financial literacy namely Knowledge (KNOW), Skills (SKIL), and Attitude (ATTI) with the business performance of SMEs. However, financial Behaviour (BEHA) had no considerable impact on the performance of SMEs. Furthermore, this study found that financial SKIL, financial KNOW, and financial BEHA have a substantial relationship with sustainable business performance, on the other hand, the ATTI had no significant impact on sustainable firm performance. As usual, the firm performance had a strong significant direct impact on sustainable firm performance. This research provides useful implications to the owner-manager by highlighting the fact that FL is essential to restore sustainable firm performance through firm performance.*

**Keywords:** Financial literacy, Firm performance, Sustainable Business Performance

## 1. Introduction

According to a study by Galindo and Méndez-Picazo, (2013) SMEs are the primary cause of new technologies and financial expansion. SMEs provide a significant job for society by expanding the market for new products, creating jobs, and facilitating social mobility in terms of income (Thurik et al., 2008; Quadrini, 1999). Since the introduction of the open economic policy in Sri Lanka in 1978, SMEs have been crucial to the growth of the country's economy. Depending on their degree of development, many nations have varied definitions for SMEs. Common indicators include total investment, Annual turnover, and total employees. An SME is defined by the SME policy framework in Sri Lanka as an organization with a maximum of 300 full-time equivalent employees and a total annual revenue of Rs.750Mn Sri Lankan Rupee (National policy framework for SME development, year).

Sri Lanka's economy relies heavily on SMEs, which make up 80% of the country's total businesses. These may be found across the economy, in the primary, secondary, and tertiary sectors, and they offer opportunities for skilled, semi-skilled, and unskilled workers alike. About 20% of all businesses are classified as SMEs, including agribusinesses that specialize in the cultivation of spices, fruits, and vegetables as well as manufacturers that participate in a wide range of different industrial operations. Almost all service providers are SMEs. SMEs are crucial to the economy since they account for around 35% of all jobs. SMEs are crucial in fostering widespread economic prosperity. On the other hand, Sri Lanka sees contributions from SMEs of over 90% of GDP, as stated (Bamunusinghe, 2022). SMEs in Sri Lanka contributes approximately 52% of GDP with 5% of exports, respectively. Meanwhile, Sri Lanka is in the midst of an economic crisis,

prompting the government to step in and implement many new rules designed to safeguard the market and the country's diverse businesses (Bamunusinghe, 2022).

The global economy's reliance on SMEs requires a deeper understanding of their performance mechanisms. Entrepreneurship nowadays focuses on corporate performance (Cassiman & Veugelers 2002; Grandinetti 2016). Despite the economic importance of SMEs and expanding research, there is limited agreement on business performance factors and practices (Grandinetti 2016). Researchers focused to form relationships and operational element hypotheses to investigate SME performance. Different perspectives may indicate a lack of generality in SME growth and performance theories. This is likely due to the complexity of SME growth and performance studies. The historical pattern suggests that academics are altering certain hypotheses as they explore (Wiklund et al., 2009).

Most people agree that SMEs need entrepreneurial capability (Wilson & Martin, 2015; Lewis, 2011). The ability to innovate and access financing are the two major pillars of entrepreneurial capability (Burke et al., 2002). In certain cases, even those who are capable of starting a business from scratch may lack the resources or the know-how to do it (Yin et al., 2015). Remund (2010) refers to FL as the capability to grasp fundamental financial ideas and to make business decisions.

To be financially literate is to have a firm grasp on fundamental financial ideas and the capacity to put those understandings to work in order to allocate resources wisely and spot market opportunities (Hung et al., 2009). However, many researchers argue that the ability to understand and manage one's financial situation is crucial to the success of any entrepreneur, especially during the crucial operations phase where revenue is generated (Wang et al., 2016).

Sustainable SMEs in developing countries struggle to grow because they lack of knowledge, skills, attitude, and awareness to handle and manage their money in a tough, apparent, and appropriate direction. Joo and Grable (2000) said owners make improper, insufficient, and unproductive business choices due to a lack of financial KNOW, a lack of available time to educate themselves on managing finances, complicated business transactions, and a comprehensive selection of financial services. SME financial obstacles can be exacerbated by poor business management. Low FL might hinder SMEs' ability to analyse and comprehend funding options and navigate complex loan application procedures.

A new way of doing business has gained widespread attention since the Sustainable Development Goal (SDGs) was first introduced in 2015. According to Schaltegger, Hansen, and Lüdeke-Freund (2012), a developing / growing company may provide societal significance, and ecological preservation by adopting a sustainable business strategy. Sustainable business models, according to Bocken et al. (2013), go beyond the maximization of shareholder profit to include the interests of a wider group of stakeholders. Small firms can increase economic growth through creating jobs, reducing poverty, redistributing money, using local resources, adapting technology, being creative, innovative, and training the workforce (Ejemeyovwi & Osabuohien 2020). For Sri Lanka to develop further, acceptable business concepts must be instilled in the country's SME.

However, numerous academics, like Schiffer and Weder (2001), Cressy (2002), and Beck et al. (2008), have suggested that SMEs' contributions to economic growth have been inadequated by their inability to gain access of financing from institutions. This is because many business owners and executives

aren't very knowledgeable about finance. So, according to De Mel et al. (2012), FL leads to the development of the financial KNOW and SKIL essential to the expansion of SMEs in underdeveloped nations (Balarezo & Nielsen, 2017; Bruhn et al., 2010).

Few research, however, has examined how FL influences business performance and sustainable firm performance separately. Hence, the main objective of this research is to examine the relationship between FL and sustainable firm performance through firm performance. In addition, the study assesses the moderating effect of industry types in the relationship between FL and sustainable firm performance.

The theoretical foundation for this research was drawn from the field of the Resource-Based View(RBV). According to this theory, business owners need to have a firm grasp of financial matters in order to acquire and arrange other resources effectively (Brinckmann et al., 2011). The theory can be used to investigate how FL influences the performance of entrepreneurs. (Szilagyi, 1980).

Moreover, most of the studies were focused differently with the following factors such as FL, financial SKIL, financial ATTI, financial BEHA, awareness, and influence on SMSs' performance in nations, both advanced and developing but no direct study on FL and SMEs success in Sri Lankan context. There are a few theories that enlighten FL and entrepreneurship, hence it is up to the researcher to come up with different ways of describing and quantifying these concepts. Thus, this study is the first to investigate areas in personal finances, such as financial KNOW, financial skill, financial ATTI, and financial BEHA, on SMEs success in Sri Lanka. The exogenous variables of this study conceptualized with four dimensions of FL namely, financial KNOW, SKIL, ATTI, and BEHA as applied by (Maroufkhani et al. 2018). Because of this, all these gaps in

empirical and methodological knowledge have been addressed by the findings of this study.

To bring a firm performance that results in sustainable firm performance, some owner-managers rely on resources especially technology, financial resources, infrastructure, etc. (Andries, 2018). However, some others focused in other resources such as market KNOW, reputation, business network, etc. (Guo, 2019). RBV emphasizes that an organization needs resources to firm performance and suitability (Barney, 1991). Despite, several studies and increasing evidence, conclusions remain mixed. Recently, however, there have been a number of studies that have placed a higher value on the characteristic of human capital/resources in the SME sector. For instance, when owner-managers are poor in financial literacy. Hence, they are unable to invest in new business, technology, infrastructure, and new products etc. (Liao & Barnes, 2015).

In addition, SMEs often struggle to maintain their focus to increase performance and attain sustainability due to a lack of public and private financial support (Khan, Yang & Waheed, 2019). Organizations can achieve maximum productivity and sustainable advantage with the help of managers who possess specialized KNOW, SKIL, and capabilities, as stated by the RBV theory (Grant, 1996). The theory puts a greater value on the capabilities, experience, and KNOW of the management team, all of which contribute greatly to the success of the firm. This research, therefore, evaluates the significance of intangible assets of FL KNOW, SKIL, ATTI, and BEHA on firm performance and sustainable firm performance.

## 2. Resource-Based View Theory

One of the most influential and well-refereed ideas in the field of administration is RBV (Barney et al., 2011). According to RBV, a company has a valuable set of assets, and some of those assets have a stronger influence on the business than others (Wernerfelt, 1984). Given that every organization has its own unique set of resources, SKIL, and competencies, the RBV of companies demonstrates that innovation is one of the

most important drivers of corporate development and expansion (Nath et al., 2010). A company's capabilities are the sum of its talents, abilities, and any supplementary KNOW that helps it achieve its goals (Sirmon et al., 2011), and in recent years, information and KNOW have come to be seen as both critical resources and flexible capabilities (Sirmon et al. 2011).

A lot drives on the company's assets and SKIL to develop competitive advantages for it to survive (Gu et al., 2016). As a result, RBV emphasizes how crucial it is for businesses to make effective use of present resources while also developing new ones to sustain their competitive advantages (Sirmon et al., 2011). Moreover, RBV takes into account both internal and external factors to boost productivity and make use of innovation to create distinctive resources and capabilities for businesses (Peteraf & Barney, 2003). The primary goal of RBV is to differentiate between competing organizations' performances that can be attributed to inherent differences in their assets (Gu et al., 2016). According to the firm's RBV, all kinds of unique asset bundles are part of any business.

## 3. Literature Review

FL means being able to make decisions that are both wise and prudent when it comes to using and managing money (Noctor et al., 1992; Beal & Delpachitra, 2003). Another way to define FL is as a component of the fundamental KNOW people need to function in contemporary society (Kim, 2001). The term "financial literacy" refers to one's capacity to understand and put into practice fundamental financial concepts (Servon & Kaestner, 2008). World Bank (2012) defines "FL as a combination of awareness, KNOW, and SKIL necessary to make proper financial decisions and achieve financial well-being". KNOW of personal money management is becoming increasingly practical. The world's complex financial and economic systems require citizens who are financially educated. Decision-makers in the economy are strongly impacted by their KNOW with various financial ideas and terminology, which is a measure of their level of financial literacy. As civilization has grown, humans have become



more capable of securing their own financial destinies.

The ability to recognize popular financial products and familiarity with fundamental financial principles are prerequisites for making prudent financial decisions. Recent research on FL demonstrates that most people lack the KNOW to make smart financial decisions (Guiso & Jappelli, 2008; Shahrabani, 2012). Conversely, a lack of FL has been linked to unwise spending and investing decisions. Stango and Zinman (2009), for instance, finding a state that a lack of financial awareness may lead to high-interest loans and an accumulation of unnecessary debt. Also, when interest rates drop, it's difficult for those who aren't financially savvy to take advantage of the opportunity to refinance (Campbell, 2006).

FL is multifaceted and has varied meanings to different researchers and academics, according to Zuhair et al. (2015), who noted that the lack of a frequently accepted definition was evidence of this. When compared to the definition of FL stated by Lusardi (2013), who states that FL is "a blend of awareness, KNOW, skill, ATTI, and BEHA essential to make full financial decisions and ultimately accomplish individual financial," the definition provided by Klapper et al., (2012) is more in line with the aforementioned definition. In an article, Schuhen and Schürkmann (2014) conveyed the most largely acknowledged definition for FL throughout the world, which consists of three fundamental pillars as financial KNOW, ATTIs, and BEHAs. In addition, Menike, (2019) identified the influence characteristic of an entrepreneur is as a major characteristic in financial literacy. FL namely, financial KNOW, financial ATTI, , financial influence, and financial BEHA as adapted by (Thapa & Raj, 2015). The ability to use financial KNOW and SKIL, as well as the right ATTI and behave in a way that is appropriate, have been demonstrated to be essential components of financial literacy, according to a number of

studies (Huston, 2010; Atkinson & Messy, 2012). People may effectively protect their financial future by acquiring and using the specific financial KNOW, SKIL, ATTI, and BEHA that are the key components of financial literacy.

#### 4. Variable Development

##### 4.1 Financial Literacy

The term "financial literacy" refers to the set of KNOW, SKIL, and information that allows business owners to handle their company's finances efficiently. Understanding how to read and write, as well as having domain-specific KNOW and SKIL, is what we mean when we talk about literacy (Atkinson, 2017). Financial literacy means making short-term and long-term money decisions and taking into account both expected and unexpected costs and income, as well as saving and investing for the future (Remund, 2010). There isn't one, agreed-upon definition of financial literacy. Instead, scholars have come up with their own interpretations of the concept. Since the concept of FL is multifaceted and has diverse meanings to different researchers and academics (Zuhair et al., 2015). People who can manage their finances well are seen as valuable assets to companies in the creative industries. Business owners can use this tool to help avoid the pitfalls of financial mismanagement (Berryman, 1983). The high percentage of small business failure is mostly attributed to the owners' inability to manage their finances effectively, according to the Global Entrepreneurship Monitor (GEM) 2010 report. SME performance is said to increase in countries where citizens are financially literate (Barte, 2012; Wise, 2013; Siekei et al., 2013). When compared to the definition of FL provided by Lusardi and Scheresberg (2013), who states that FL is "a blend of awareness, KNOW, skill, ATTI, and BEHA essential to make full financial decisions and ultimately accomplish individual financial wealth," the definition provided by Klapper et al., (2012) is more in line with the aforementioned definition. FL is defined by Schuhen and Schürkmann (2014) as "the information, ATTIs, and BEHAs necessary to manage one's

personal and professional financial affairs effectively”.

The dimension of FL has been categorized by the previous researchers into main dimensions such as financial KNOW, financial SKIL, financial ATTI, financial BEHA, awareness, and financial influence. The researcher describes below the development of constructs consisting of independent variables dimensioned from FL(financial KNOW, financial SKIL, financial ATTI, and financial BEHA) mediating variable: business performance and dependent variable: sustainable business performance.

Besides, the variables of FL in this study were conceptualized and operationalized and measured using the dimensions of KNOW, SKIL, ATTI, and BEHA as adopted from (Bongomin et al., 2018; Atkison & Messy, 2014; Lusardi & Mitchell, 2014). In addition, Kempson (2008) distinguished between the functional components of FL and the progression from KNOW to SKIL to ATTIs to BEHA. In a summary, KNOW would cover the reason for saving and the means to do it, SKIL the ability to create a saving plan, ATTI the willingness to save in advance, and BEHA the practice of setting aside some funds.

#### 4.2 Financial Knowledge

Financial KNOW is defined as the Learning of fundamentals of personal finance is essential to living a comfortable and secure life (Huston, 2010). Financial KNOW is playing a crucial role on how to handle money. Those who have financial KNOW of the economics behind the most pressing concerns in their field of expertise are more likely to succeed than their less financially savvy counterparts. In other words, it allows them to effectively handle monetary concerns related to the performance of their enterprise. Being financially literate means having a clear understanding on the fundamentals of financial management in order to successfully run a business (Eniola & Entebang, 2017), understanding finance and how it works (Lusardi & Mitchell, 2006), being able to apply that understanding (Hung, Parker, & Yoong, 2009), and finally, being financially

independent (Lusardi & Michell, 2006) are all necessary components of being financially literate (Huston, 2010).

The financial KNOW dimension includes income generation, cost cutting, increase assets, and minimizing debt (Kiyosaki & Lechter, 2000). This requires the owner-manager to make sense of a number of seemingly elementary financial concepts, such as interest, the value of discounts and cost-sharing, and return on investment. Budgeting, investing, financial planning, keeping accurate records, and maintaining specific types of bank accounts are all part of the FL component here.

#### 4.3 Financial Skill

the fundamentals of finance is referred "financial KNOW," whereas "financial SKIL" is the capacity to apply that KNOW to real-world situations. The technical KNOW employed and shaped in routines of financial self-management represented these SKIL (Pellinen et al., 2011), FL encompasses a wide range of competencies, from proficiency in figuring out compound interest to calculating interest (Kunovskaya, 2010) and inflation (Sekita, 2011) to the competence of securing the best possible terms in business deals while planning ahead (Kunovskaya, 2010; Chaulagain, 2015; Lusardi & Mitchell, 2014).

Managers who understand income, financial planning, budgeting, saving, and investing may make better short-term financial decisions and build solid long-term plans. (Remund, 2010). Many researchers argue that business owners of SMEs benefit from financial literacy, or the development of financial KNOW and SKIL since it allows them to make better financial decisions. Njoroge and Gathungu (2013) stated that those who are financially skilled are less likely to make poor management decisions with their money. Strong financial management is crucial to the survival and management of SMEs, and FL SKIL enables business leaders to evaluate financial products and make wise decisions.

#### 4.4 Financial Attitude

A financial ATTI has referred a person who takes into account monetary realities while making choices and allocating resources

(Ragina, Ezat, Junid, & Moshiri, 2011). Financial ATTI, such as aversion to risk and a focus on time, as well as some aspects of one's social context and formal education, might boost firm performance. Managers of smaller companies that are eager to improve their bottom lines by learning more about financial management will increase their firm performance. KNOW of finances has been proposed as a necessary element for a manager to have a healthy financial ATTI (Hathaway & Khatiwada, 2008). It has been theorized that a manager's financial ATTI will improve if he or she has a firm grasp of the financial ATTI (Eniola & Entebang, 2017).

#### 4.5 Financial Behaviour

Financial BEHA, as defined by Zeynep (2015), is "the ability to capture of comprehend the entire implications of financial actions on one's condition and to make the proper judgments associated with cash management, safeguards, and opportunities for budget planning." Individuals' financial BEHA as measured by various indicators may be reliably predicted by their level of financial literacy, as several studies have proven (Hung, Parker & Yoong, 2009).

According to Sucuahi (2013), competent financial BEHA is defined as the capacity to generate wealth and prevent uncertainty in organizations and people. These measures increase one's financial assets, safeguard against going into debt over one's head, provide for one's retirement, and protect one's financial stability against important life events.

#### 4.6 Sustainable Firm Performance

firm performance is measured by an organization's capacity to live up to the hopes and dreams of its customers and other stakeholders via careful planning, informed decision-making, and creative problem-solving. A company's long-term performance depends on its capacity to produce organizational KNOW, manage KNOW in a competitive environment, deal with environmental unpredictability, generate organizational intelligence, and control the supply chain (Civelek et al., 2015). Thus,

running a business is about more than just creating a profit for the proprietor; it's also about doing things the right way, and that requires everyone involved to accept responsibility for their part. An organization's sustainability should be based on improving efficiency, social importance, localization and engagement, stability, being socially responsible, and work enrichment (Wells, 2013; Upward & Jones, 2016).

Indicators of sustainability evaluate the results of a company's actions regarding its business model and the degree to which those decisions contribute to sustainability (Abdelkafi & Tauscher 2016). Businesses that are sustainable make sustainability a central tenet of their value offering and their reasoning for creating value. Therefore, they benefit both their clientele and the world at large (Geissdoerfer, Vladimirova, & Evans 2018). Five propositions characterize sustainable business models: i) Benefits to the economy, society, and the environment are all considered when calculating sustainable value. (ii). To be really sustainable, business models must create a system of mutually beneficial exchanges of resources and benefits between numerous parties, including the natural environment and the human community. (iii). They call for a rethought value chain in terms of its goals, architecture, and leadership. (iv). They necessitate taking into account the needs and roles of all relevant parties across the board in order to maximize value for everyone involved. Business externalities (v) and product-service systems (vii) foster creativity and new approaches to creating sustainable businesses (Evans et al., 2017).

Creating social value and protecting the environment inside a successful company are both aspects of sustainable business performance (Schaltegger, Hansen, & Lüdeke-Freund, 2012). Using a framework developed by (Paulraj et al., 2011). There were able to quantify the economic, environmental, and social performance of sustainable firms. According to Paulraj (2011), the economic indicator (materials purchased, energy consumption, waste discharge, return on investment)

environmental indicator (air emission, waste, consumption for hazardous, frequency for environmental accidents, and energy saving), and social indicators (stakeholder welfare, community health and safety, risks, occupational health and safety, and awareness and protection) were used as measures. The goal of sustainable business performance is to "generate consumer and societal value by combining social, environmental, and commercial operations" (Bocken et al., 2013). Delivering financial value to stakeholders is only one aspect of sustainable company performance.

#### 4.7 Firm Performance

The term "performance" can be used to indicate a variety of things, such as development, maintenance, achievement, or even rivalry. The term "performance" refers to a company's success in producing desired results and activities (Eniola & Entebang, 2015). The term "business performance" refers to the degree to which a company is able to realize its goals as determined by comparing actual outputs with those projected. This includes financial results, market standing, and shareholder return (Richard et al., 2009). When a company meets or exceeds the goals and expectations it set with its investors at the beginning of a given time period, it is said to have achieved "business performance," which is synonymous with "market success" (Eniola, 2015; Begonja et al., 2016).

The firm performance, according to Chamwada, (2015) may be determined by tracking three indicators: the rate of growth in revenue, the value of the company's assets, and the number of full-time workers. With regards to SMEs, it is about the concept of performance, and more specifically, the definition of performance. Performance can lead to two different strategic outcomes, which are commonly referred to in the literature as company success and failure (Abiodun & Harry, 2016). Managers can use firm performance as a proxy for the quality of management (Jennings & Beaver, 1997; Sefiani & Bown, 2013). Whether or whether a business has been successful is determined by how well it has accomplished its objectives (Davidsson, 2004).

Performance is used as a measure of a company's viability throughout a specific time frame, as stated by (Eniola & Entebang, 2015). Due to this, performance has become an important concern for SME. Strategically bettering a company's performance depends on a number of factors, including the management team's ability to recognize and capitalize on new opportunities as they arise, its flexibility in responding to environmental shifts, and its possession of other traits such as innovativeness in product development, creativity, proactivity, technological advancement, and social networking.

There has been much discussion on how to measure business performance, but no agreed-upon metrics have emerged. The traditional measures of a company's performance, however, include both monetary and non-monetary metrics. Profitability indicators such as return on asset, return on sales, return on investment, return on equity, market share and operational efficiency are examples of financial indicators (Gentry & Shen, 2010). Job satisfaction, loyalty to the company, employee turnover, and business owners' happiness are all indicators of performance beyond the bottom line (Mayer & Schoorman, 1992). There is an understanding that business owners, especially those running smaller operations, often shield their company's financial performance metrics from public view for reasons of secrecy (Sabana, 2014).

Factors that shape a company's direction are called determinants of business performance (Simpson et al., 2012). As a result, measuring and evaluating business performance is crucial in today's competitive business environment, as stated by (Mabhungu & Van Der Poll, 2017). In addition, Javed and Muhammad (2011) noted that measuring business performance is an improved method for investigating whether a business enterprise is developing by means of indicators which permit an easy way to look into the enterprise situation. These indicators include the annual sale turnover rate, growth, number of employees, innovation, competition, and availability of resources. Profitability, growth, innovativeness, and



survival were the most common indicators of business performance in the corporate world (Feng et al., 2017).

Client service quality, customer satisfaction, employee contentment, and environmental and social impact are non-financial indicators of success (Kaymak & Bektas, 2017). In the long run, non-financial performance metrics can have an impact on the efficiency and profitability of a business (Eccles, Ioannou, & Serafeim, 2014; Ho, Wu, & Wu, 2014). Gielnik et al. (2016) argued, however, that in addition to traditional

indicators like "economic growth," such metrics should also take into account what the business owners themselves consider to be performance. In addition, Feng et al. (2017) argued that only objective measures of a company's performance should be embraced, meaning that performance in business should be measured by factors like increased sales and staff proficiency. In keeping with these points of view, the researcher of this study wants to focus on nonfinancial indicators of firm performance.

**Conceptual Framework**

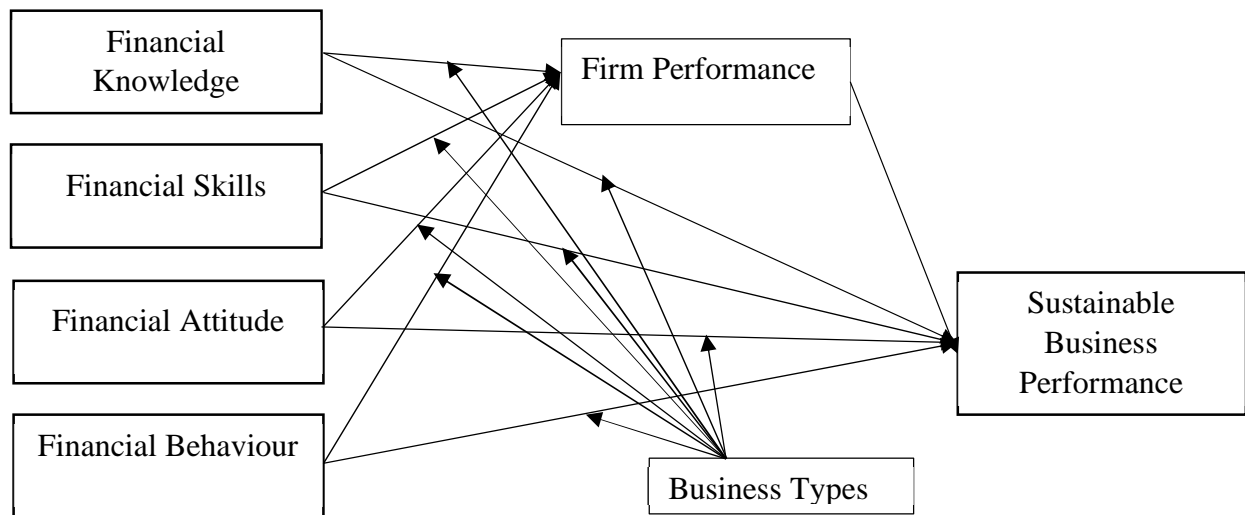

Figure 1 – Conceptual Framework

**5. Hypothesis Development**

**5.1 Financial Literacy and Firm Performance**

According to research by Kidwell and Turrisi (2004), firms whose owners have a deeper understanding of finance are better able to keep accurate financial records and secure funding from other sources. Increased access to capital is one benefit of FL for businesses (Marcolin & Abraham, 2006). Owner-managers who lack financial expertise will have a difficult time directing their businesses' finances successfully. Therefore, each decision taken by the company's management has the potential to alter the firm's performance. Studies on the impact of FL on the performance of SMEs have drawn the conclusion that a lack of financial KNOW is a major factor in the failure of many businesses throughout the world (Bunyaminu, Tuffour, &

Barnor, 2019; Tuffour & Martey, 2019). SMEs play an outsized role in the economies of many countries; therefore, a manager's financial SKIL and practices may have an impact on the success of its operations in the future (Sucuahi, 2013). According to Agyapong and Attram (2019) sound financial KNOW, SKIL, ATTI, and awareness to manage and direct the finances of their firms in a good direction, transparent, and professional way is significant to the firm.

According to Ajzen (1991), a person's financial ATTI is the individual's propensity to act in a certain way that was created owing to some economic and non-economic views the person had about the consequence of certain conduct. Higher levels of financial optimism are associated with the following BEHAs and ATTIs: a greater propensity to save (Atkinson and Messy, 2012; Agarwalla et al., 2013),

lower inflation expectations (Bruine de Bruin et al., 2010), a lower propensity to consume (Atkinson and Messy, 2012; Agarwalla et al., 2013), and higher risk tolerance (Lusardi & Mitchell, 2008; Yu et al., 2015).

How a person behaves has a major impact on his or her financial situation. High financial BEHA individuals also save more frequently and routinely, invest in the stock market, and use other formal financial markets (Van Rooij et al., 2007; Klapper et al., 2012; Bucher-Koenen et al., 2016). What makes a company capable is its ability to arrange and bring together various resources, typically in some sort of combination, via the use of organizational processes that result in improved performance (Grant, 1996). Those mechanisms are based on KNOW unique to the company and are thus mostly intangible. They have evolved over time as a result of complex interactions between the firm's resources (Amit & Schoemaker, 1993; Conner, 1991; Prahalad & Hamel, 2006). They can be viewed as the firm's KNOW and the ATTIs and beliefs it fosters, all of which contribute to the company's ability to attract and retain a wide variety of resources (both financial and non-financial), to survive difficult economic and social environments, and to improve performance.

FL as including four dimensions KNOW (Lusardi & Bassa Scheresberg, 2013); SKIL (Kunovskaya, 2010; Sekita, 2011; Kunovskaya, 2010; Lusardi & Mitchell, 2014); ATTI (Sabri & MacDonald, 2010); and BEHA (Atkinson & Messy, 2012; Klapper et al., 2012; Agarwalla et al., 2013). Hence, the following hypotheses were developed.

- H1 – Higher Financial knowledge leads to an influence on firm Performance
- H2 – Higher Financial skill leads to an influence on firm Performance
  - Higher financial attitude leads to an influence on firm Performance
- H4 – Higher financial behaviour leads to an influence on firm Performance

## 5.2 Financial Literacy and Sustainable Firm Performance

Many research has tried to prove that FL is vital to the performance and sustainable firm performance of SMEs (Deakins & Hussain 1994). According to Beal and Delpachitra (2003), FL is a crucial competency since it allows individuals to navigate the financial markets with confidence and competence and eliminates misunderstandings about issues. When business leaders are financially literate, their companies benefit because they have easier access to capital and are less likely to suffer losses due to bad decision-making. Due to inexperience with accounting information systems and poor financial statement preparation, many small business owners have their loan applications rejected (Deakins & Hussain 1994). Preparing standard financial accounts and providing useful information to all stakeholders, including bankers and lenders, in a timely manner improves a small business owner's prospects of securing financial resources. Small business owners that are financially literate are better able to prepare for loan applications, present compelling arguments during client interviews, and adapt to a dynamic business and financial markets environment (Lusardi & Mitchell 2011). For technical purposes, FL improves SMEs' access to resources, lowers finance costs, and allows for the development of a sound capital structure, all of which contribute to the long-term viability of the business (Areo, Gershon, & Osabuohien 2020).

In spite of the fact that the impact of FL on SME performance has been widely documented, the same cannot be said about its impact on corporate sustainability or sustainable business model (Lusardi & Mitchell 2011; Eniola & Entebang 2017). Beyond financial literacy, the prior research also looked at financial competence, which includes things like financial KNOW and SKIL as well as money management abilities (OECD 2016). People that are financially adept have a positive mentality when it comes to handling their finances. They keep an eye on the economy, adapt their decisions to the

current climate, and take measures to better their financial situation. As business owners show they can responsibly handle their finances and make educated choices, they will be able to keep their sustainable business (Borg, 2017).

Research on SMEs financing has repeatedly indicated that a lack of capital is an issue for SME owners. Financial illiteracy may be a hindrance for business owners, making it harder for them to secure funding and keep track of their earnings. Those who are not financially Knowledgeable tend to avoid investing and other financial decisions because they feel overwhelmed (Agarwal, Chomsisengphet, & Lim 2017). FL as including four dimensions of KNOW (Lusardi & Bassa Scheresberg, 2013); SKIL (Kunovskaya, 2010; Sekita, 2011; Kunovskaya, 2010; Lusardi & Mitchell, 2014); ATTI (Sabri & MacDonald, 2010); BEHA (Atkinson & Messy, 2012; Agarwalla et al., 2013).

Managers of SMEs would do well to equip themselves with financial literacy, financial expertise, and financial data that would allow them to secure the external financing that is the key to competitive advantage (Hussain, Salia & Karim, 2018). Financially literate managers are a boon to the SME sector in emerging economies because they can better allocate resources, resulting in better performance (Malinda et al., 2018). For example, the KBV theory proposes that businesses with managers who are Knowable, skilled, and informed have better benefits in performance and competitive advantage. FL has been found to have a substantial positive correlation with sustainable firm performance in a number of studies (Purnomo, 2019). Since this is the case, the study makes the hypothesis that

H5- Higher financial knowledge leads to the influence on Sustainable firm performance

H6- Higher financial skills lead to the influence on Sustainable firm performance

H7- Higher financial attitude leads to the influence on Sustainable firm performance

H8- Higher financial behaviour leads to the influence on Sustainable firm performance

### **5.3 Firm performance and Sustainable firm performance**

The success of SME is said to improve firm performance when its owners are financially literate (Barte, 2012; Wise, 2013; Siekei et al., 2013). Firm performance is measured by financial and nonfinancial indicators (Runyan et al., 2012; Rauch et al., 2009; Stam et al., 2014).

A person's FL is an intangible resource that aids in their ability to manage their own finances and make sound investment choices (Greenspan, 2002). Both resources tangible and intangible with respect to FL are crucial to gain an edge in the marketplace and succeed as an entrepreneur with superior performance. There is a contradicting causal relationship between firm performance and sustainable firm performance. In addition, a company's participation in sustainability initiatives in the following term is a direct result of its financial performance in the preceding period. If a company's financial performance has been strong in the past, it will have extra money to put into sustainability initiatives; if it has not, the company will not even consider taking such measures. All firms, high and low, have a common short- and long-term causal relationship between performance and sustainability (Chang & Kuo, 2008).

Higher sustainability performance has been linked to a company's success, according to several studies. So, for instance, Rodgers et al. (2013) found that the value of a company's performance has a major impact on CSR in the modern era. Chang and Kuo (2008) found that the stronger a company's financial performance, the better its sustainability practices, and the same holds true for the other way around. In addition, some academics have concluded that social investment undermines the core idea of growing a company's worth (Jensen, 2001).

H6: Firm performance has a significant relationship on Sustainable firm performance.

## 6. Research Design, Data Collection, and Analysis

An organization's resources interact in complex ways over time to create something called a "firm-specific intangible process" (Prahalad & Hamel, 2006). The firm's own KNOW, SKIL, ATTIs, and BEHAs, as well as the strategic resilience and support for the firm's superior performance and sustained firm performance, are examples of these intangible assets.

The research method that follows describes constructing measurements for the FL constructs, firm performance, and sustainable firm performance as well as the data collection procedure for empirical testing. Confirmatory factor analysis and hypothesis testing using covariance-based path coefficients were utilized in structural equation modelling for instrument validation.

The constructs used in this study are financial literacy, firm performance, and sustainable firm performance. For each construct, it was identified items that were used from previous research. The testing was used as perceptual measures rather than objective measures for firm performance and sustainable firm performance. Because it is difficult to isolate both due to FL as changes in performance. In a similar vein, Tallon et al. (2000) stated that executives' subjective assessment can stand in for substantial evidence.

Accordingly, in this research, FL was characterized by financial KNOW, financial SKIL, financial ATTI, and financial BEHA. In which, financial KNOW was measured by four items (Knowledgeable about financial risks, Knowledge about costs associated with financial products/services, Knowledge of key features of financial products/services, and Knowledge about financial statements): SKIL was measured with three items (ability to prepare a personal budget, ability to accurately determine benefits and cost from financial dealings, and evaluating the different financial products and services); ATTI was measured with three items (good attitude towards saving money, organized in regards to managing money, and well prepared for the future risk); BEHA was measured with four items (always

read the terms and conditions on use of financial products/ services, always keep aside some money for their future use, always choose financial products that suits their needs and Conditions and always look to saving and spending money).

The firm performance construct was measured by four items, as described in the literature section: profitability, growth, innovation, and survival (Feng et al., 2017). Finally, sustainable firm performance was measured by three items: Environmental sustainability, financial sustainability, and social responsibility (Babajide et al., 2021; Habib, Bao & Ilmudeen, 2020).

the eastern province, data was gathered using predetermined and organized mail survey questionnaires. The questionnaire's face validity was initially improved through pilot testing with a small sample of experienced owner-managers. These firm owners and managers shared the same educational and occupational backgrounds as the real responders and displayed a high level of business and financial Knowledge. In addition, respondents were involved with analyzing the phrasing of each scale item for clarity and purpose before making suggestions for improvements. The respondent reached a consensus on the constructs and items, indicating that the measurement scales had sufficient face validity. A researcher specializing in accounting was asked to comment on and critique the updated questionnaire.

The refined questionnaire was sent to 600 randomly selected owner managers from the SME registered in the Chamber of Commerce of each district (Ampara:383, Batticaloa:83, Trincomalee: 418) in the Eastern Province, Sri Lanka, along with a letter explaining the study objective and assuring participants' privacy. They were chosen because there was a need for the target respondents to possess both Knowledge relevant to their companies.

Participants were asked to indicate the degree to which they agreed or disagreed with statements made regarding the concepts on a Likert scale running from 1 (strongly disagree)



to 5 (strongly agree). It was requested that the questionnaire be returned via postal mail. Two weeks following the initial letter, a reminder was issued to those who had not yet replied. Almost 25 of the surveys had unusable responses due to incomplete responses. The data was collected from 260 respondents, at a response rate of 43.33%. Among the 285 responses, 260 were considered for analysis after the screening of data. The reliability and construct validity of each variable was tested by using SPSS, version 26.0. The reliability of the individual items in each construct was measured with Cronbach alpha against the alpha coefficient which was higher than 0.7 and thus internal consistency was attained.

To examine the construct validity of the measurement models of each variable, confirmatory factor analysis(CFA) was done.

**7. Descriptive Analysis**

Table1: Descriptive Analysis

Demographic Variables	Sub-items	Frequency	Percentage
Gender	Male	204	78.46
	Female	56	21.54
Qualification	A/L Completed	95	36.54
	Diploma	79	30.38
	Bachelor Degree	64	24.62
Experiences	Master Degree	22	8.46
	1 To 3 Years	32	12.31
	3 To 6 Years	34	13.08
	6 To 9 Years	173	66.54
Position	More than 9 years	21	8.08
	Manager	52	20.00
	Owner / Proprietor	152	58.46
	Partner	32	12.31
	Chairman	9	3.46
Business Types	Director	15	5.77
	Trading	100	38.46
	Service	64	24.61
	Manufacturing	49	18.84
Business Operation	Construction	47	18.07
	1 To 3 Years	15	5.77
	4 To 7 Years	72	27.69
	8 To 12 Years	115	44.23
Number of Employees	More than 12 Years	58	22.31
	0 To 10	85	32.73
	11 To 50	61	23.46
	51 To 150	35	13.46
Annual Turnover	More than 150	35	13.46
	Less than 15 Mn	127	48.85

Before doing CFA, it is important to check the Explorative Factor Analysis (EFA). The Kaiser-Meyer-Olkin (KMO) value, Bartlett’s Test of Sphericity for sample adequacy, and factor loadings for internal consistency were done for the purpose of confirming EFA. The measurement model’s integrity of fit was measured with Chi-square/df <3, GFI > 0.9, AGFI>0.9, CFI>0.9, and RMSEA<0.08 values (hair et al., 2010). When the overall measurement model is accepted (Chi-square/df< 3, fit indices >0.9 and RMSEA< 0.08), all the factor loadings were more than 0.5 and the discriminant validity is satisfied, the structural model was developed and goodness-of-fit was evaluated. Then by using AMOS, version 26.0 SEM was used for hypotheses testing and validation.

15 Mn To 50 Mn  
50 Mn To 100 Mn  
100 Mn To 250 Mn

The above table depicts the percentage of gender participants including 78.46 % (204) male and 21.54(56) female. Further, it shows the educational qualification of the participant who has A/L completed as the highest percentage of 36.54(95), next to the highest is the diploma holders percentage of 30.38 (79), the lowest percentage of the participant who has master degree completed .typically the general owner possess bachelor degree at 24.62 (64) percentage.

The owner-managers have different years of experience in their firm. The table depicts that the owner-managers highest year of experience included 66.54(173) in 6 to 9 years, 13.08% ( 34) in 3 to 6 years, 12.31% in 1 to 3 years and the lowest is 8.08% (21) in more than 9 years of experience.

The distribution of business types in the study included 38.46%(100) in trading (wholesales, retails, imports and distribution, distribution, modern shops), 18.84%(49) in manufacturing, 24.61%(64) in service, and the lowest is 18.07% (47) in construction. The table indicates that in the majority of the forms approximately

61.15%(159) of the respondent have 11 to 50 employees, about 24.23%(63) respondents have below 10 employees, and 13.46%(35) respondents have 51 to 150 employee in their firm. The lowest number of employees are in more than 150. The table finally indicates that the majority of the respondents' firms earn less

### Measurement model

Table 2: Measurement and criteria

Variables	Items	Factor Loading	AVE	CR
Financial Behaviour	BEH1	.896	.756	.925
	BEH2	.851		
	BEH3	.877		
	BEH4	.854		
Financial Knowledge	KNO1	.811	.723	.912
	KNO2	.851		
	KNO3	.895		
	KNO4	.841		
Financial Attitude	ATT1	.891	.770	.909
	ATT2	.877		
	ATT3	.864		
Financial Skills	SKI1	.974	.661	.849
	SKI2	.824		
	SKI3	.596		
Firm Performance	FIP1	.874	.799	.941
	FIP2	.914		
	FIP3	.891		
	FIP4	.897		
Sustainable Firm Performance	SFP1	.809	.734	.892
	SFP2	.880		
	SFP3	.880		

According to Hair et al. (2010), the measurement model was tested using construct reliability convergent validity and discriminant validity. Composite reliability and Cronbach alpha of the construct were used to measure the construct reliability of the model. The composite reliability of the measurement model ranged between .849 to .925 (see table 2) and the factor loading value of the construct in between .596 to .914 which is above the threshold level (>0.5). Hence the measurement model is fit and reliable for further testing (Hair et al., 2014).

According to Fornell and Larcker, (1981) the average variance extracted (AVE) was used to

measure the convergent validity of each construct. The values of AVE of all constructs were above the threshold value >0.5. This shows that the convergent validity of the measurement model is fit (Hair et al., 2014). Finally, the discriminant validity of the model was tested. It shows (see table 3) that all the diagonal values (AVE) are higher than their highest squared correlation with any other construct (Fornell & Larcker, 1981). In this, the AVE as the diagonal value is greater than the off-diagonal squared correlation in the rows and columns, signifying the fulfillment of the Fornell-larcker criterion (See Table 3). Hence, the discriminant validity of the constructs is satisfied.

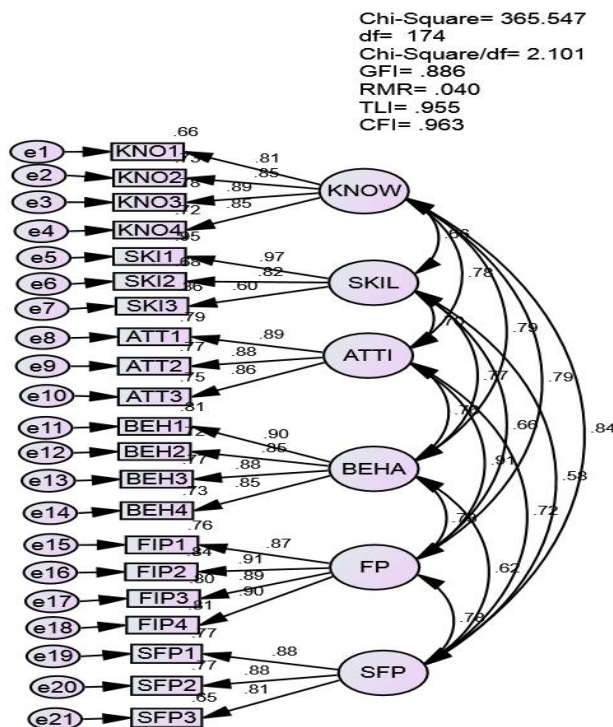

Figure 2: Measurement Model

Table 3: Discriminant validity of the construct

	KNOW	SKIL	ATTI	BEHA	FP	SFP
KNOW	0.723					
SKIL	0.437	0.661				
ATTI	0.605	0.494	0.770			
BEHA	0.624	0.590	0.581	0.756		
FP	0.630	0.436	0.651	0.533	0.799	
SFP	0.701	0.339	0.518	0.382	0.605	0.734

Note: The diagonal data in the Matrix represents the square of correlation of the construct.

**Structural Equation Modelling and hypothesis testing**

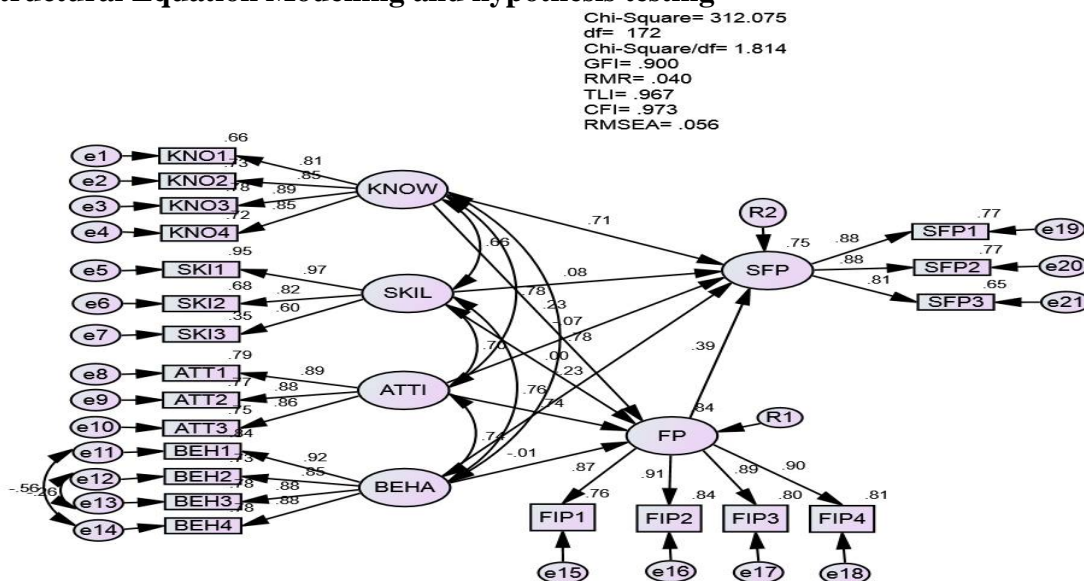

Figure 3: Structural Model

Table 4 : Results of Hypothesis

Hypothesized Path	Relationship	Std Estimate	UnStd. Estimate	S.E.	C.R.	P	Hypothesis Result
H1	FP <---KNOW	.335	.504	.067	7.533	***	Supported
H2	FP <---SKIL	.581	.530	.114	4.460	***	Supported
H3	FP <---ATTI	.799	.921	.065	14.155	***	Supported
H4	FP <---BEHA	.044	.062	.054	1.154	.248	Not Supported
H5	SFP <---KNOW	.644	.727	.076	9.533	***	Supported
H6	SFP <---SKIL	.089	.340	.171	1.986	.047	Supported
H7	SFP <---ATTI	.008	.007	.091	.078	.938	Not Supported
H8	SFP <---BEHA	.160	.167	.050	3.316	***	Supported
H9	SFP <---FP	.332	.249	.085	2.914	.004	Supported

The structural model was tested using AMOS 26 analysis. The SEM is a good fit for the data used in this study. There are some criteria which were used to test the model for example. Chi-square fit, CMIN/ df= 1.814 which is below the cut of point of 3. Hence, the model is fitted in line with Chi-square value to the degree of freedom. Then the other criteria were used such as TLI, CFI, and GFI which values are .967, .973, and .900 respectively, which are greater than 0.9 (Hair et al., 2014). RMSEA is 0.047 which is lesser than 0.08 and RMR is 0.040 which is less than 0.50. Thus, the structural model is a valid model (See figure 2).

As shown in Table 2 above most of the relationships are significant. However, based on 1000 bootstrap resamples as recommended by Hair et al., (2014), the nexus between FL and firm performance and the nexus between FL and sustainable firm performance. Most of the variables are significant at 0.05 (See Table 4). The path coefficients show that ATT significantly impacts on FP (Std estimate= .799, CR=14.155,  $p = 0.000 < 0.000$ ) and KNOW significantly impacts on FP (Std estimate= .335, CR=7.533,  $p < 0.000$ ), the relationship between SKIL and FP (Std estimate= .581, CR=4.460,  $p = 0.000 < 0.000$ ), confirming H1, H2, and H3. In contrast, the relationship between BEHA and FP (Std estimate= .044, CR=1.154,  $p = .248 < 0.05$ ) confirms that BEHA (H4) do not significant with FP respectively. Further to test the significant impact on SFP of exogenous variable: the path coefficient shows that the

impact of BHAV on SFP (Std estimate= .160, CR=3.316,  $p = 0.000 < 0.000$ ): KNOW significant impact on SFP (Std estimate= .644, CR=9.533,  $p = 0.000 < 0.000$ ): INF significant impact on SFP on SFP (Std estimate= .089, CR=1.986,  $p = 0.047 < 0.05$ ): confirming that H5, H6, and H7 are supported. Finally, to test the relationship between FP and SFP, the path coefficient shows that FP significantly impacts of SFP (Std estimate= .332, CR=2.914,  $p = 0.004 < 0.05$ ) confirming H9 that FP has a significant impact on SFP.

The coefficient of determination ( $R^2$ ) is a statistical indicator of the extent to which a linear regression model can be explained by a set of exogenous variables (Chicco et al., 2021). Based on what we see in Figure 3, the SEM's coefficient of determination ( $R^2$ ), The model explains a large proportion of the variation in both the FP (75%) and SFP (84%) dependent variables, indicating its validity.  $R^2$  values above 0.10 are recommended by (Falk & Miller, 1992). The model satisfies the criterion for endogenous variables set forth by (Falk & Miller, 1992). Since the model still has a sizeable fraction of unexplained variability, it could benefit from the addition of new, critical components. According to Hair et al., (2014),  $R^2$  values greater than 67% are considered a higher variance explained. The model used in this study explains more variance of FP and SFP.



**Examining Mediating Effects**

To measure a complex integrated structural model, it is important to test the mediating effect between constructs. This section is intended to test the mediating effect of FP between ATT, BHA, KNOW, and SFP, and these were tested separately. According to Hair et al.(2014), there should be robust associations among the exogenous variable, the mediator, and the endogenous variables. The direct and indirect effects were considered when analyzing the mediating effect. However, according to the conceptual model of this study, there is a need a study to measure full and partial mediation between variables

**Mediation effect of FP between KNOW and SFP**

standardized regression weight and the finding table (2) revealed that the direct relationship between KNOW and FP has a significant relationship. Meantime, the relationship between KNOW and SFP has a significant relationship. As both paths have a significant relationship, it is needed to test partial mediation. The 95% CI for the indirect impact of KNOW on SFP is (lower= 0.027, upper= 0.200). The number 0 does not fall within the range (Memon, 2018). As a result, KNOW influences SFP. Therefore, FP is a mediator between KNOW and SFP (P=0.023 <0.05)(see Tables 5 and 6). Therefore, H9a, FP mediates the relationship between KNOW and SFP is supported with partial mediation.

**Mediation effect of FP between SKIL and SFP**

Based on the standardized regression weight, the findings (Table 2) revealed that

there is a significant relationship between SKIL and SFP and there is a significant relationship between SKIL and FP. The 95% CI for the indirect impact of SKIL on SFP is (lower= 0.105, upper= 0.174). The number 0 does not fall within the range (Memon, 2018). As a result, SKIL influences SFP. Therefore, FP is a mediator between SKIL and SFP (P= 0.035 <0.05) )(see Tables 5 and 6). Therefore, H9b, FP mediates the relationship between SKIL and SFP is supported with partial mediation.

**Mediation effect of FP between ATTI and SFP**

Because of the standardized regression weight, the findings (Table 2) revealed that there is no significant relationship between ATTI and SFP and there is no significant relationship between ATTI and FP. The 95% CI for the indirect impact of ATTI on SFP is (lower= 0.081, upper= 0.505). The number 0 does not fall within the range (Memon,2018). As a result, ATTI influences SFP. Therefore, FP is a mediator between ATTI and SFP (P= 0.021 <0.05) )(see table 5 and 6). Therefore, H9c, FP mediates the relationship between ATTI and SFP is supported with full mediation. As the other variable: BEHA has no significant relationship with FP and a significant relationship with SFP, it can be concluded that there is no mediation effect. Further, table 5, it shows that the lower bound and upper bound value of both SKILL and BEHA has 0 value. As a result, there is no mediation effect for the variable.

Table 5: Unstandardized Indirect Effect

	KNOW	SKIL	ATTI	BEHA
FP	...	...	...	...
SFP	.023	.035	.021	.825

Table 6: Indirect Effects Analysis Using 1000 Bootstrap

	95% Lower Bound						95% Upper Bound					
	KNOW	SKIL	ATTI	BEHA	FP	SFP	KNOW	SKIL	ATTI	BEHA	FP	SFP
FP	.000	.000	.000	.000	.000	.000	.000	.000	.000	.000	.000	.000
SFP	.027	.105	.081	-.058	.000	.000	.200	.174	.505	.060	.000	.000

Table 7: Moderating effect of ‘Business Types’

Model	NPAR	CMIN	DF	P	CMIN/DF
Unconstrained	236	1023.384	688	.000	1.487
Measurement weights	191	1080.308	733	.000	1.474
Structural weights	164	1110.389	760	.000	1.461
Structural covariances	134	1143.715	790	.000	1.448
Structural residuals	128	1156.623	796	.000	1.453
Measurement residuals	59	1261.466	865	.000	1.458
Saturated model	924	.000	0		
Independence model	84	6162.017	840	.000	7.336

The moderating effect of business types was examined using four types of groups: trading, services, manufacturing, and constructs. Based on the moderation test, it showed that the chi-square(1023.384) for unconstrained

was lower than the measurement residual(1261.466)(see table 7). The output indicated that there was a moderation effect on the model.

Table 8: Assuming model Unconstrained to be correct:

Model	DF	CMIN	P	NFI Delta-1	IFI Delta-2	RFI rho-1	TLI rho2
Measurement weights	45	56.924	.109	.009	.010	-.002	-.002
Structural weights	72	87.005	.110	.014	.016	-.004	-.004
Structural covariances	102	120.331	.104	.020	.022	-.005	-.006
Structural residuals	108	133.239	.050	.022	.024	-.005	-.005
Measurement residuals	177	238.082	.001	.039	.043	-.004	-.005

The measurement residual showed a significant p= 0.001 <0.05(see table 8). It showed that there was a significant moderating effect between business types

(Trading, Service, Manufacturing, and Construction) towards exogenous and endogenous variables.

Table 9: Table Regression Weight of the Moderating Variables

	Trading		Service		Manufacturing		Construction	
	Estimate	P	Estimate	P	Estimate	P	Estimate	P
FP <--- KNOW	.052	.870	.602	.067	.224	.172	.820	.004
FP <--- SKIL	.904	.203	.352	.616	.285	.633	.497	.559
FP <--- ATTI	1.366	***	.988	***	.965	***	.708	.017
FP <--- BEHA	.328	.347	.073	.709	.005	.972	.260	.400
SFP <--- KNOW	1.073	***	.526	.077	.887	***	.949	.002
SFP <--- SKIL	.477	.392	.573	.314	.337	.653	1.412	.064
SFP <--- ATTI	.174	.510	.061	.829	-.820	.189	.045	.874
SFP <--- BEHA	.645	.021	.027	.862	.360	.056	.206	.444
SFP <--- FP	.336	.013	.289	.229	.965	.084	.086	.655

Based on the above table 9, it showed that the moderating effect of business types for trading towards exogenous variables consisted of (ATTI, SKIL, KNOW, and BEHA) and as for endogenous variable SFP and FP. It showed

that business types only act as a moderator for ATT to FP(p=0.00), HEHA to SFP(p=0.021), KNOW to SFP (p=0.000), and FP to SFP (p=0.013) with beta value 1.366, 0.645,1.073 and 0.336 respectively.

Similarly, for service business type, it showed that the moderating effect of business types for services towards exogenous variables consisted of (ATTI, SKIL, KNOW, and BEHA) and for endogenous variables SFP and FP. It showed that business types act as a moderator for ATT to FP( $p=0.00$ ), with a beta value of 0.988.

While examining, it showed that the moderating effect of business types for manufacturing towards exogenous variables consisted of (ATTI, SKIL, KNOW, and BEHA) and as for endogenous variable SFP and FP. It showed that business types act as a moderator for ATT to FP( $p=0.00$ ), and KNOW to SFP ( $p=0.000$ ) with beta values of .965 and 0.887 respectively.

Finally, it showed that the moderating effect of business types for construction towards exogenous variables consisted of (ATTI, SKIL, KNOW, and BEHA) and for endogenous variable SFP and FP. It showed that business types act as a moderator for ATT to FP( $p=0.017$ ), KNOW to FP ( $p=0.004$ ), and KNOW to SFP( $p=0.002$ ) with beta values 0.708, 0.802 and 0.949 respectively

## 7. Conclusion and Recommendation

SMEs have a significant impact on the national economy. Hence, the owner-managers of the SMEs are the key decision maker to take the organization toward success. FL is one of the important concepts to determine firm performance and sustainable firm performance. The organization's success is measured by its performance. The hypothesized conceptual model was developed by adapting the RBV theory to measure the relationship between FL and firm performance, financial literacy, and sustainable firm performance, and firm performance and sustainable firm performance. In addition, the second objective was to examine the mediating impact of firm performance in the relationship between FL and sustainable firm performance. Finally, a moderating role of business types was tested on firm performance and sustainable firm performance with financial literacy.

This study test nine hypothesis derived from the conceptual framework of financial literacy, firm performance, and sustainable firm performance. The study concludes that a significant influence was found by the three dimensions of financial literacy; KNOW, SKIL, and ATTI with firm performance while financial BEHA did not show a significant impact on the firm performance of SME. Further, this study reveals that financial SKIL, financial KNOW, and financial BEHA have a strong relationship with sustainable firm performance while ATTI did not show a significant impact on sustainable firm performance. Finally, to test the direct effect, the firm performance had a strong significant impact on sustainable firm performance. Further, the model was used to assess the mediating effect of firm performance in the relationship between FL and sustainable firm performance. The study concluded that firm performance mediates the relationship between financial ATTIs and sustainable firm performance is supported by full mediation. And also firm performance mediates the relationship between financial KNOW and sustainable firm performance is supported with partial mediation. Moreover, firm performance mediates the relationship between SKIL and sustainable firm performance with partial mediation while firm performance did not mediate the relationship between BEHA and sustainable firm performance.

The theory of KBV emphasizes that owner-manager with sufficient Knowledge, skill, and information direct their firm to improve profitability and sustainability (Barney, 1991). Moreover, RBV emphasizes the importance of tangible and intangible assets of the firm to gain sustainable and better performance. Prior studies stated that intangible assets (KNOW, SKIL, information, and capabilities) drive toward superior performance (Khan, Yang, & Waheed, 2019). This study focused on the KNOW of the owner-manager for higher performance and sustainable firm performance.

Moreover, the result confirmed that financial KNOW significantly contributes to firm performance and sustainable firm performance. Other studies are also consistent with the finding that it shows a significant positive influence of FL on sustainable firm performance (Purnomo, 2019). Further, this study is consistent with the finding of (Memon, Yong An, and Memon, 2019), who revealed that a manager who has FL will have high capabilities to find opportunities and new ideas which can bring high performance. Hence, this study has revealed that financial KNOW, SKIL, and financial ATTI are supported by firm performance, and further, it revealed that Financial KNOW, Financial SKIL, and Financial BEHA, have a significant influence on sustainable firm performance. Therefore, strengthening FL is crucial to the blueprint for success in enhancing entrepreneurial performance (Adomako & Danso, 2014; Kojo Oseifuah, 2010; Glaser & Walther, 2013).

Further, the research reveals that financial BEHA has not a significant influence on firm performance, at the same time it has a significant influence on sustainable firm performance. The findings, as a result, stand in contrast to the conclusions of Potrich et al. (2016), who came to the conclusion that the financial behaviour of SMEs has a considerable impact on the company's performance. Even though, the majority of the owner-manager respondents and significant relationship of financial KNOW, SKIL, and financial ATTI on firm performance, however, they have no opinions about their financial BEHA.

Moreover, financial SKIL have a significant relationship with firm performance and sustainable firm performance. Financial SKIL might have a positive effect on the future of the business (Sucuahi, 2013), and the finding is consistent. The study of Chatterjee and Das (2016) showed a negative effect of skill on the commercial success of Indian micro-enterprises, which goes against the outcome that was found here. Financial SKIL might have a positive effect on the future of the business (Sucuahi, 2013). Additionally,

of SME growth are undoubtedly human capital and financial SKIL (Maroufkhani et al., 2018; Perks, 2010).

Business performance has been shown to boost economic, environmental, and social outcomes in numerous research (Eltayeb et al., 2011; Foo et al., 2018). In line with their conclusions, this research found that FL and company performance are significantly related to firm sustainable performance. This finding is in line with the conclusion of another study that explained a positive correlation between firm performance and sustainable firm performance. Short-term firm performance is correlated with long-term sustainability across all low- and high-performing enterprises (Chang, & Kuo, 2008). Some studies have found a causality relationship between sustainability and firm performance, both in the other direction (from firm performance to sustainability) and in the positive direction (from sustainability to firm performance).

According to the literature (Ullmann, 1985; McGuire, 1988; Waddock, Graves, 1997), a company needs additional capacity to engage in sustainability initiatives (according to the RBV theory, a company needs to make a profit in order to invest in things that aren't directly related to making money). In addition, a company's financial performance in one period will influence its participation in sustainability efforts in the following time. If a company has a history of strong financial success, it is more likely to prioritize sustainability initiatives with that extra money. If the company has a poor financial track record, it is less likely to prioritize sustainability initiatives.

Some studies have shown that if a company is doing well financially, it will also do well in terms of sustainability. According to a survey conducted by Chang and Kuo (2008), the two concepts are positively intertwined; better higher financial performance tend to correlate with sustainability practices and vice versa.

In this study, a further test was applied to measure the moderating effect of business types (Trading, Service, Manufacturing, and Construction) with financial literacy, firm performance, and sustainable firm



performance. Hence, it was hypothesized that business types moderates the relationship between financial literacy, firm performance, and sustainable firm performance. The finding shows that ATT and BEHA of business types moderate the effect of firm performance. Further, a trading organization under business types moderates the relationship between KNOW and SFP, and FP SFP. Similarly, service organizations under business type moderate FP and SFP. Further, manufacturing organization under business type moderates ATTI and FP, KNOW, and FP. Finally, construction organizations under business types moderate ATT, KNOW with FP, and KNOW and SFP.

This study revealed that the owner-managers help when choosing a financing option, budgeting, costing, and making decisions about production. The acquisition and use of the proper financial knowledge have the power to boost productivity, expand market share, and boost sales revenue. In the end, this would encourage venture development and survival, giving the company a competitive advantage.

The creation of FL education initiatives helps investors, legislators, managers, and employees of businesses become more financially literate. FL programs are being introduced by many organizations to assist managers in improving their financial KNOW, SKIL, ATTI, and BEHA. Contrarily, several businesses also offer financial counseling services to investors after evaluating their risk tolerance and profile. The study's findings suggest that managers and politicians should concentrate on creating investor profiles based on personality attributes.

The findings will highly be helpful to owner-manager of SMEs as they prepare to archive the objectives set that direct the firms toward success. One main finding from this research is that SME managers need to emphasize the significance of FL and work to help their staff become more financially literate. If this were to happen, it would improve in the training of owner-managers both now and in the future in terms of financial literacy.

The results can be applied theoretically. This research adds to the RBV theory by defining FL as crucial to performance and sustainable firm performance. Further, in the RBV theory, intangible assets like FL add a new dimension of this study by aligning with firm performance that improves sustainable firm performance. In addition, the study enhances the body of knowledge by using the RBV theory to demonstrate the importance of financial knowledge and abilities for the owner/manager if the enterprise is to have a competitive advantage over rivals in the same industry.

Policymakers were urged to enhance funding for economic and entrepreneurial education in national education systems in light of the correlation found in this article. There is a substantial correlation between FL and sustainability. Given the significance of financial KNOW, SKIL, ATTI, and BEHA in the lives of citizens, the benefits of FL go far beyond the purely economic issue. It is recommended that FL be given a higher priority in educational systems around the world in order to preserve sustained success in economic disciplines.

Finally, there are business implications derived from this study. Because human capital and financial KNOW, financial SKIL, and financial ATTI obviously become the main area of SMEs' growth, governments and educational institutions should prioritize training and education programs on FL for entrepreneurs to provide supportive entrepreneurial sustainability. And since it has been shown that exposure to financial facilities increases business owners' knowledge of money concerns, governments and financial service organizations may make it easier for business owners to gain access to a wider range of financial products and services.

There are some limitations to this study. The first thing to note is that the sample size for this study was (260 responses) and focused in the Eastern Province in Sri Lanka. Second, other factors, such as age, gender, level of experience, etc., may moderate the proposed association between the constructs.

However, these moderating factors are ignored. Human capital, customer relations, and innovation are just a few examples of non-financial intangible assets that have been extracted by researchers into common metrics that can be used in the throughput model to evaluate the correlation between sustainability and business success. Hence, Future research can consider deeply the indicators of the dimension (financial, social, and environmental) of sustainable firm performance. This may bring a clear understanding of these indicators. Further, future studies can consider both financial and non-financial measures over the long run to examine firm performance and sustainable firm performance. The incorporation of this intangible asset performance into a more general theoretical framework can lead to surprising findings.

#### References

- Abdelkafi, N., & Tauscher, K. (2016). Business Models for Sustainability from a System Dynamics Perspective. *Organization & Environment*, 29(74), 96. doi:10.1177/1086026615592930.
- Abiodun, E.A., & Harry .E. (2016). Harry Finacia Literacy and SME firm performance. *International Journal of Research Studies in Management*, 5(1), 31-43.
- Adomako, S. & Danso, A. (2014). Finacia Literacy and firm performance: the moderating role of financial capital availability and resource flexibility. *International Journal of Management and Organizational Studies*, 3(4), 1-15.
- Agarwalla, S.K., Barua, S.K., Jacob, J. & Varma, J.R. (2013). Finacia Literacy among working young in urban India, IIMA Working Paper 10(2), 1-27.
- Agyapong, D., & Attram .A.B. (2019). Effect of owner-manager's Finacia Literacy on the performance of SMEs in the Cape Coast Metropolis in Ghana. *Agyapong and Attram Journal of Global Entrepreneurship Research*, 9(67), 1-13. <https://doi.org/10.1186/s40497-019-0191-1>
- Ajzen, I. (1991). The theory of planned behavior. *Organizational Behavior and Human Decision Processes*, 50, 179-211.
- Amit, R., & Schoemaker, P.J.H. (1993). Strategic Asset and Organizational Rent. *Strategic Management Journal*, 14, 33-46. <https://doi.org/10.1002/smj.4250140105>
- Andrieş, A., Marcu, F. N., Oprea, & Tofan, M. (2018). Financial Infrastructure and Access to Finance for European SMEs. *Sustainability*, 10 (10), 3400
- Areo, O. S., Gershon, O., & Osabuohien, E. (2020). Improved Public Services and Tax Compliance of Small and Medium Scale Enterprises in Nigeria: A Generalised Ordered Logistic Regression, *Asian Economic and Financial Review*, 10(7), 833-860. <https://doi.org/10.18488/journal.aefr.2020.107.833.860>
- Atkinson, A. & Messy, F.A. (2012). Measuring financial literacy: results of the OECD/ international network on financial education (INFE) pilot study, OECD Working Papers on Finance, Insurance and Private Pensions, 15, 1-73.
- Atkinson, A., & Messy, F.-A. (2014). OECD / INFE Evidence, Policies and Practice 2013. Oecd, 34, 55. [www.oecd.org/daf/fin/wp](http://www.oecd.org/daf/fin/wp)
- Atkinson, A. (2017). Financial Education for MSMEs and Potential Entrepreneurs, OECD Working Papers on Finance, Insurance and Private Pensions, No. 43, OECD Publishing, Paris, <https://doi.org/10.1787/bb2cd70c-en>.
- Babajide, A., Osabuohien, E., Tunji-Olayeni, B., Falola, H., Amodu, L., Olokoyo, F., Adegboye, F., & Ehikioya, B. (2021). Financial literacy, financial capabilities, and sustainable business model practice among small business owners in Nigeria. *Journal of Sustainable Finance & Investment*, DOI: [10.1080/20430795.2021.1962663](https://doi.org/10.1080/20430795.2021.1962663)
- Bamunusinghe, R. (2022, May 30). New initiative to help Sri Lankan SMEs grow. <https://www.sundaytimes.lk/220130/business-times/new-initiative-to-help-sri-lankan-smes-grow-470589.html>
- Balarezo, J. & Nielsen, B.B. (2017). Scenario planning as organizational intervention: an integrative framework and future research directions. *Review of International Business and Strategy*, 27(1), 2-52.
- Barney J., (1991). Special theory forum the resource-based model of the firm: origins, implications, and prospects. *Journal of Management*, 17(1), 97-98.
- Barney, J. (1991). Firm resources and sustained competitive advantage. *Journal of Management*, 17(1), 99-120.
- Barte, R. (2012). FLin micro-enterprises: the case of Cebu fish vendors. *Philippine Management Review*, 19.

- Beal DJ, Delpachitra SB (2003). Finacia Literacy among Australian university students. *Economic Papers: A Journal of Applied Economics and Policy*, 22(1):65-78
- Berryman, J. (1983). Small Business Failure and Survey of the Literature. *European Small Business Journal*, 1(4), 47-59.
- Bocken, N. M. P., Short, P. S., Rana, & Evans. S. (2013). A Value Mapping Tool for Sustainable Business Modelling." Corporate Governance. *The International Journal of Business*, 13, 482–497. doi:10.1108/CG-06-2013-0078.
- Bocken, N., Short, S., Rana, P., Evans, S. (2013). A value mapping tool for sustainable business modelling. *Corporate Governance*, 13 (5), 482 – 497.
- Bongomin, G. O. C., Munene, J. C., Ntayi, J. M., & Malinga, C. A. (2018). Nexus between Fland financial inclusion: Examining the moderating role of cognition from a developing country perspective. *International Journal of Bank Marketing*, 36(7), 1190-1212.
- Brinckmann, J., Salomo, S., & Gemuenden, H. G. (2011). Financial management competence of founding teams and growth of new technology-based firms. *Entrepreneurship Theory and Practice*, 35(2), 217–243. <http://dx.doi.org/10.1111/j.1540-6520.2009.00362.x>
- Bruine de Bruin, W., Vanderklaauw, W., Downs, J.S., Fischhoff, B., Topa, G. & Armantier, O. (2010). Expectations of inflation: the role of demographic variables, expectation formation, and financial literacy. *The Journal of Consumer Affairs*, 44(2), 381-402.
- Bucher-Koenen, T., Lusardi, A. & Alessie, R.J. (2016). How financially literate are women? An overview and new insights, *GFLEC Working Paper*, 1, 1-37.
- Bunyaminu, A., Tuffour, J. K. & Barnor, C. (2019). Assessing the determinants of business failure of companies listed on the Ghana Stock Exchange. *Journal of Accounting and Finance*, 19(4), 39–54.
- Burke, A.E., Fitzroy, F.R. & Nolan, M.A. (2002). Self-employment wealth and job creation: the roles of gender, non-pecuniary motivation, and entrepreneurial ability. *Small Business Economics*, 19(3), 255-270.
- Campbell John. Household Finance. *Journal of Finance*. 2006;61:1553–1604
- Central Bank of Sri Lanka, Annual Report, (2011)
- Cassiman, B., & Veugelers, R. (2002). R&D cooperation and spillovers: some empirical evidence from Belgium. *American Economic Review*, 92(4), 1169-1184.
- Chamwada, V.K., (2015). The Effect of Finacia Literacy on Financial Performance of Small and Micro Enterprises In Kibera Slums, Nairobi County
- Chang, D.; Kuo, L.L.(2008). The Effects of Sustainability Development on Firms' Financial Performance An Empirical Approach. *Sustain. Dev.*, 16, 365–380.
- Chatterjee, N., & Das, N. (2016). A study on the impact of key entrepreneurial skills on business success of Indian micro-entrepreneurs: A case of Jharkhand region. *Global Business Review*, 17(1), 226– 237.
- Chicco, D., Warrens, M.J. & Jurman, G. (2021). The coefficient of determination R-squared is more informative than SMAPE, MAE, MAPE, MSE and RMSE in regression analysis evaluation. *PeerJ Computer Science*, 7, 623.
- Civelek, Mustafa Emre; Çemberci, Murat; Artar, Okşan Kibritci; & Uca, Nagehan, (2015). Key Factors of Sustainable Firm Performance: A Strategic Approach" Zea E-Books. Book 34.
- Conner, K. (1991). Historical comparison of resource-based theory and five schools of thought within industrial organization economics: Do we have a new theory of the firm?. *Journal of Management*, 17(1), 121-154.
- Cressy, R.C. (2002). Funding gaps: an introduction. *The Economic Journal*, 112(477),1-16.
- Davidsson, P. (2004). Researching entrepreneurship. Boston, MA: *Springer Science Business Media Inc.*
- Deakins, D. & Hussain, G. (1994). Risk assessment with asymmetric information. *The International Journal of Bank Marketing*, 12(1), 24-31.
- De Mel, S., McKenzie, D. & Woodruff, C. (2012). Business training and female enterprise start-up, growth, and dynamics: experimental evidence from Sri Lanka, World Bank Policy Research Working Paper No 6145.
- Eccles, Robert G., Ioannis Ioannou, and George Serafeim. (2014). The Impact of Corporate Sustainability on Organizational Processes and Performance. *Management Science*, 60(11), 2835–2857.
- Ejemeyovwi, J. O., & Osabuohien, E. S. (2020). Investigating Mobile Technology Adoption and Inclusive Growth in West Africa. *Contemporary Social Science*, 15(1), 48-61. <https://doi.org/10.1080/021582041.2018.1503320>
- Eltayeb, T., Zailani, S. & Ramayah, T. (2011). Green supply chain initiatives among certified companies in Malaysia and environmental sustainability: Investigating the outcomes,

- Resources. *Conservation and Recycling*, 55, 495-506.
- Eniola, A. A., & Entebang, H. (2017). SME managers and financial literacy. *Global Business Review*, 18(3), 1-18.
- Evans, Steve, Doroteya Vladimirova, Maria Holgado, Kirsten Van Fossen, Miying Yang, A. Elisabete, & Claire Y. Silva. (2017). Business Model Innovation for Sustainability: Towards a Unified Perspective for Creation of Sustainable Business Models. *Business Strategy and the Environment*, 26 (5): 597-608.
- Falk, R.F. & Miller, N.B. (1992), A Primer for Soft Modeling, University of Akron Press.
- Feng, H., Morgan, N. A., & Rego, L. L. (2017). Firm capabilities and growth: the moderating role of market conditions. *Journal of the Academy of Marketing Science*, 45, 76-92.
- Fornell, C. & Larcker, D.F. (1981). Evaluating structural equation models with unobservable variables and measurement error. *Journal of Marketing Research*, 18(1), 39-50.
- Galindo, M.Á. & Méndez-Picazo, M.T. (2013). Innovation, entrepreneurship and economic growth. *Management Decision*, 51(3), 501-514.
- Geissdoerfer, M., D. Vladimirova, and S. Evans. (2018). Sustainable Business Model Innovation: A Review. *Journal of Cleaner Production*, 198: 401-416. doi:10.1016/j.jclepro.2018.06.240.
- Gentry, R. J., & Shen, W. (2010). The relationship between accounting and market measures of firm financial performance: How strong is it?. *Journal of managerial issues*, 514-530
- Gielnik, M. M., Zacher, H., & Schmitt, A. (2016). How Small Business Managers' Age and Focus on Opportunities Affect Business Growth: A Mediated Moderation Growth Model. *Journal of Business Management*, 00, 1-24.
- Glaser, M. & Walther, T. (2013), Run, walk, or buy? Financial Literacy, Dual-Process Theory, and Investment Behavior, Technical Report, LMU, Munich.
- Grandinetti, R. (2016). Absorptive capacity and knowledge management in small and medium enterprises. *Knowledge Management Research & Practice*, 14(2), 159-168.
- Grant R.M., (1996). Toward a knowledge-based theory of the firm. *Strategic management journal*, 17 (S2), 109-122.
- Guiso, Luigi, Jappelli, and Tullio. (2008). Finacial Literacy and portfolio diversification, European University Institute, Department of Economics, Working Paper ECO 2008/31,1-36.
- Guo Y., et al., (2019). The mediating role of environmental innovation on knowledge acquisition and corporate performance relationship: A study of SMEs in China. *Sustainability*, 11(8), 2315.
- Habib, M.A., Bao, Y. & Ilmudeen, A. (2020). The impact of green entrepreneurial orientation, market orientation and green supply chain management practices on sustainable firm performance. *Cogent Business and Management*, 7, 174-616.
- Hathaway, I., & Khatiwada, S. (2008). Do financial education programs work? (Working Paper No. 08-03). Cleveland, OH: Federal Reserve Bank of Cleveland.
- Hung, A., Parker, A. & Yoong, J. (2009). Defining and measuring financial literacy, RAND Working Paper No. WR-708.
- Hung, A. A., Parker, A. M., & Yoong, J. (2009). Defining and measuring financial literacy. Santa Monica, CA: RAND Corporation.
- Huston, S.J. (2010). Measuring financial literacy. *The Journal of Consumer Affairs*, 44(2), 296-316.
- Hussain, J., Salia, S., & Karim, A. (2018). Is knowledge that powerful? Financial literacy and access to finance: An analysis of enterprises in the UK. *Journal of Small Business and Enterprise Development*, 25(6), 985-1003. <https://doi.org/10.1108/JSBED-01-2018-0021>
- Javed Mahmood Jasra, & Muhammad Asif Khan, A. I. H. (2011). Determinants of Business Success of Small and Medium Enterprises. *Journal, International*, 2, 274- 280.
- Jennings, P., & Beaver, G. (1997). The performance and competitive advantage of small firms: A management perspective. *International Small Business Journal*, 15(2), 63-28. <http://dx.doi.org/10.1177/0266242697152004>
- Jensen, M. (2001). Value maximization, stakeholder theory, and the corporate objective function. *Eur. Finance. Manag.*, 7, 297-317.
- Joanna L.Y. Ho, Anne Wu, Steve Y.C. Wu, (2014). Performance measures, consensus on strategy implementation, and performance: Evidence from the operational-level of organizations, Accounting. *Organizations and Society*, 39(1), 38-58.
- Joo, S. H., & Grable, J. E. (2000). Improving employee productivity: The role of financial counseling and education. *Journal of Employment Counseling*, 37(1), 2-15. <http://dx.doi.org/10.1002/j.2161-1920.2000.tb01022.x>



- Kempson, E. (2008). Financial Education Fund: Fund Management Inception Report. Paris, France: Financial Education Fund. <http://www.oecd.org/dataoecd/0/41/42271820.pdf>
- Khan S.Z., Yang Q., & Waheed A., (2019). Investment in intangible resources and capabilities spurs sustainable competitive advantage and firm performance. *Corporate Social Responsibility and Environmental Management*, 26(2), 285–295.
- Kidwell, Blair, and Robert Turrisi. (2004). An examination of college student money management tendencies. *Journal of Economic Psychology*, 25, 601–16.
- Kim, Jinhee. (2001). Financial Knowledge and Subjective and Objective Financial Well-being. *Consumer Interests Annual*, 47: 1–3. [http://www.consumerinterests.org/files/public/Kim-Financial knowledge.pdf](http://www.consumerinterests.org/files/public/Kim-Financial%20knowledge.pdf).
- Kiyosaki, R. & Lechter, S. (2000). *Rich Dad Poor Dad*, Warner Books Ed., New York, NY.
- Klapper, L. F., Lusardi, A., & Panos, G. A. (2012). Financial literacy and the financial crisis. (No. w17930). National Bureau of Economic Research
- Kojo Oseifuah, E. (2010). Financial literacy and youth entrepreneurship in South Africa. *African Journal of Economic and Management Studies*, 1(2), 164–182. <https://doi.org/10.1108/20400701011073473>
- Kunovskaya, I. (2010). The impact of financial literacy on use of financial services in Russia, Doctoral dissertation, available at: [https://getd.libs.uga.edu/pdfs/kunovskaya\\_irina\\_201005\\_phd.pdf](https://getd.libs.uga.edu/pdfs/kunovskaya_irina_201005_phd.pdf) (accessed 10 April 2017).
- Lewis, H. (2011). A model of entrepreneurial capability based on a holistic review of the literature from three academic domains. *Industry and Higher Education*, 25(6), 429–440.
- Liao Y. & Barnes J., (2015). Knowledge acquisition and product innovation flexibility in SMEs. *Business Process Management Journal*, 21(6), 1257–1278.
- Lusardi, A., & de Bassa Scheresberg, C. (2013). Financial Literacy and high-cost borrowing in the United States, NBER Working Paper n. 18969, April.
- Lusardi, A., & Mitchell, O. S. (2014). The economic importance of financial literacy: Theory and evidence. *Journal of Economic Literature*, 52(1), 5–44. <https://www.aeaweb.org/articles?id=10.1257/jel.52.1.5>
- Lusardi, A. & Mitchell, O. (2008). Planning and financial literacy: how do women fare? *American Economic Review*, 98(2), 413–417.
- Lusardi, A. & Mitchell, O.S. (2011). Financial Literacy and retirement planning in the United States, CeRP Working Paper No. 107,1–27.
- Lusardi, A., & Michell, O. S. (2006). Financial Literacy and planning: Implications for retirement wellbeing (Pension Research Council Working Paper No. 1). Amsterdam, Netherlands: Wharton School, University of Pennsylvania.
- Lusardi, A. & Mitchell, O.S. (2014). The economic importance of financial literacy: theory and evidence. *Journal of Economic Literature*, 52(1), 5–44.
- Mabhungu, I., & Van Der Poll, B. (2017). A Review of Critical Success Factors Which Drives the Performance of Micro, Small and Medium Enterprises. *International Journal of Business and Management*, 12, 151
- Malinda. S., Masyita.D., Rahman.S., & Anwar.M.(2018). Financial Literacy and Work Engagement as Mediating Variable to Bank Agent's Performance. *European Research Studies*, 21, 503–518.
- Marta Begonja, Filip Čiček, Bernardo Balboni & Ani Gerbin (2016). Innovation and business performance determinants of SMEs in the Adriatic region that introduced social innovation. *Economic Research-Ekonomska Istraživanja*, 29(1),1136-1149, DOI:10.1080/1331677X.2016.1213651
- McGuire, J.J., Sundgren, A.,& Schneeweis, T. (1988). Corporate social responsibility and firm financial performance. *Academy of Management Journal*, 31, 854–872.
- Marcolin, S. & Abraham, A. (2006). Financial literacy research: Current literature and future opportunities. Proceedings of the 3rd International Conference on Contemporary Business Conference, Leura NSW; 21–22 September, <http://ro.uow.edu.au/commpapers/223>, accessed 29 January 2013.
- Mayer, R., & Schoorman, F. (1992). Predicting participation and production outcomes through a two-dimensional model of organizational commitment. *Academy of Management Journal*, 35: 671–684.
- Memon, M.A., Chea, J., Ramayah, T., Ting, H., & Chua, F. (2018). Mediation analysis: issues and recommendations, *Journal of Applied structural equation modelling*, 2(1), retrieved from [https://jasemjournal.com/wp-content/uploads/2019/10/JASEM\\_12Editorial-Memon-et-al.-2018.pdf](https://jasemjournal.com/wp-content/uploads/2019/10/JASEM_12Editorial-Memon-et-al.-2018.pdf)
- Memon A., Yong An Z., & Memon M.Q., (2019). Does financial availability sustain financial, innovative, and environmental performance? Relation via

- opportunity recognition. Corporate Social Responsibility and Environmental Management., 54,102190, <https://doi.org/10.1016/j.ijinfomgt.2020.102190>.
- Menike, L.M.C.S., (2019). Effect of Finacia Literacy on Firm Performance of Small and Medium Enterprises in Sri Lanka. Financial Markets & Corporate Governance Conference, Available at SSRN: <https://ssrn.com/abstract=3306719> or <http://dx.doi.org/10.2139/ssrn.3306719>
- Nath, P., Nachiappan, S. & Ramanathan, R. (2010). The impact of marketing capability, operations capability and diversification strategy on performance: a resource-based view. *Industrial Marketing Management*, Vol. 39, No. 2, pp.317–329.
- Njoroge, C.W. & Gathungu, J.M. (2013). The effect of entrepreneurial education and training on development of small and medium size enterprises in Githunguri District – KENYA. *International Journal of Education and Research*, 1(8),1-22.
- Noctor, M., Stoney, S. and Stradling, R. (1992). National Westminster Bank. (1992), 'Financial Literacy: A Discussion of Concepts and Competences of fiancail literacy and Opportunities for its Introduction into Young People's Learning', Report prepared for the National Westminster Bank, National Foundation for Education Research, London.
- OECD. (2013). Organization for Economic Co-Operation and Development. *Finacail literacy and inclusion: Results of OECD/INFE survey across countries and by gender*. OECD Centre, Paris, France.
- OECD (2014). PISA 2012 technical background, in OECD (Ed.), PISA 2012 Results: Students and Money: Financial literacy Skills for the 21st Century, Vol. VI, OECD Publishing, Paris,123-145.
- OECD-INFE(2011), Measuring Financial Literacy: Core Questionnaire in Measuring Financial Literacy: Questionnaire and Guidance Notes for Conducting an Internationally Comparable Survey of Financial Literacy, OECD Publishing, Paris.
- Okeke, A. M., Nto, P. O., & Mbanasor, J. A. (2015). Analysis of the Factors Influencing Savings and Investment Behaviour among Yam Entrepreneurs in Benue State, Nigeria. *European Journal of Business and Management*, 7(27), 205-210.
- Parisa Maroufkhani, Ming-Lang Tseng, Mohammad Iranmanesh, Wan Khairuzzaman Wan Ismail, Haliyana Khalid. (2020). Big data analytics adoption: Determinants and performances among small to medium-sized enterprises. *International Journal of Information Management*, Volume 54,102190, <https://doi.org/10.1016/j.ijinfomgt.2020.102190>.
- Paulraj, A. (2011). Understanding the relationships between internal resources and capabilities, sustainable supply management and organizational sustainability. *Journal of Supply Chain Management*, 47(1), 19–37. <https://doi.org/10.1111/jscm.2011.47>.
- Pellinen, A., Tormakangas, K., Uusitalo, O. & Raijas, A. (2011). Measuring the financial capability of investors: a case of the customers of mutual funds. *International Journal of Bank Marketing*, 29(2),107-133.
- Perks, S. (2010). Problem-solving techniques of growing very small businesses. *Journal of Enterprising Communities: People and Places in The Global Economy*, 4(3), 220-233.
- Peteraf, M.A., Barney, J.B., (2003). Unraveling the resource-based tangle. *Manag. Decis. Econ.* 24 (4), 309–323. <https://doi.org/10.1002/mde.1126>.
- Potrich, A.C.G., Vieira, K.M. & Kirch, G. (2015). Determinants of financial literacy: analysis of the influence of socioeconomic and demographic variables. *Revista Contabilidade & Finanças*, 26(69), 362-377.
- Prahalad, C. K., & Hamel, G. (2006). The core competence of the corporation. In D. Hahn & B. Taylor (Eds.), *Strategische unternehmungsplanung — strategische unternehmungsführung*, 275–292. Berlin/Heidelberg: Springer-Verlag. [http://dx.doi.org/10.1007/3-540-30763-X\\_14](http://dx.doi.org/10.1007/3-540-30763-X_14)
- Purnomo B.R., (2019). Artistic orientation, fiancail literacy and entrepreneurial performance. *Journal of Enterprising Communities. People and Places in the Global Economy*, 13(1/2), 105–128.
- Quadrini, V. (1999).The importance of entrepreneurship for wealth concentration and mobility. *Review of Income and Wealth*, 45(1), 1-19.
- Ragina, A., Ezat, W. P., Junid, S. A., & Moshiri, H. (2011). Financial management attitude and practice among the medical practitioners in public and private medical service in Malaysia. *International Journal of Business and Management*, 6(8), 105–113.
- Remund, D.L. (2010). Finacia Literacy explicated: the case for a clearer definition in an increasingly complex economy. *The Journal of Consumer Affairs*, 44(2), 276-295.
- Richard et al. (2009). Measuring Organizational Performance: Towards Methodological Best Practice. *Journal of Management*, 35, 718-804.<https://doi.org/10.1177/0149206308330560>

- Rodgers, W.; Choy, H., & Guiral, A.(2013). Do Investors Value a Firm's Commitment to social Activities?. *Journal of Buisness Ethics*, 113, 607–623.
- Runyan, R., Ge, B., Dong, B., & Swinney, J. (2012). Entrepreneurial orientation in cross-cultural research: assessing measurement invariance in the construct. *Entrepreneurship Theory and Practice*, 36, 819–836.
- Sabana, M. B. (2014). Entrepreneur financial literacy, financial access, transaction costs and performance of micro enterprises in Nairobi City County, Kenya.
- Sabri, M. F., & MacDonald, M. (2010). Savings behavior and financial problems among college students: The role of financial literacy in Malaysia. *Cross-Cultural Communication*, 6(3), 103-110. <http://dx.doi.org/10.3968/j.ccc.1923670020100603.009>
- Schaltegger, Stefan & Lüdeke-Freund, Florian and Hansen, Erik G., (2012). Business Cases for Sustainability: The Role of Business Model Innovation for Corporate Sustainability (2012). *International Journal of Innovation and Sustainable Development*, 6(2), 95-119, Available at SSRN: <https://ssrn.com/abstract=2010510>
- Schiffer, M. & Weder, B. (2001). Firm size and the business environment: worldwide survey results, IFC Discussion Paper Number 43.
- Schaltegger, S., E. Hansen, & F. Lüdeke-Freund. (2012). Business Cases for Sustainability and the Role of Business Model Innovation. *International Journal of Innovation and Sustainable Development*. 6, 95–119.
- Schuhen M, & Schürkmann. S (2014). Construct validity of financial literacy. *International Review of Economics Education* 16(A): 1–11.
- Sefiani, & Bown. (2013). What influences the success of manufacturing SMEs? A perspective from Tangier. *International Journal of Business and Social Science*, 4(7).
- Sekita, S. (2011). Financial literacy and retirement planning in Japan, Report No. 01/2011-016, Network for Studies on Pensions, Aging and Retirement, available at: <http://arno.uvt.nl/show.cgi?fid=114074> (accessed 2 April 2017).
- Servon, Lisa J., Kaestner, & Robert (2008). Consumer Financial Literacy and the impact of online banking on the financial behavior of lower-income bank customers. *Journal of Consumer Affairs*, 42(2), 271-305.
- Shahrabani, & Shosh. (2012). The effect of financial literacy and emotions on intent to control personal budget: a study among Israeli college students. *International Journal of Economic Finance*, 4(9), 156-163.
- Sieki, J., Wagoki, J. & Kalio (2013). An Assessment of the role of Financial Literacy on performance of small and micro enterprises: case of Equity Group Foundation Training Program on SMES in Njoro district, Kenya. *Journal of Economics and Finance (JEF)*, 1(7), 250-259.
- Simpson, M., Padmore, J. & Newman, N. (2012). Towards a new model of success and performance in SMEs. *International Journal of Entrepreneurial Behavior & Research*, 18(3), 264-285. <https://doi.org/10.1108/13552551211227675>
- Sirmon, D.G., Hitt, M.A., Ireland, R.D., & Gilbert, B.A. (2011). Resource orchestration to create competitive advantage: breadth, depth, and life cycle effects. *Journal of Management*, 37, 1390– 1412.
- Stam, W., Arzlanian, S., & Elfring, T. (2014). Social capital of entrepreneurs and small firm performance: A meta-analysis of contextual and methodological moderators. *Journal of Business Venturing*, 29(1), 152– 173.
- Stango, V. and Zinman, J.(2009). Exponential Growth Bias and Household Finance. *Journal of Finance*, 64, 2807- 2849.
- Sucuahi, W. T. (2013). Determinants of financial literacy of micro entrepreneurs in Davao city. *International Journal of Accounting Research*, 1(1), 44–51.
- Tallon, P. P., Kraemer, K. L., & Gurbaxani, V. (2000). Executives' Perceptions of the Business Value of Information Technology: A Process-Oriented Approach. *Journal of Management Information Systems*, 16(4), 145-173. <https://doi.org/10.1080/07421222.2000.11518269>
- Thapa, B.S., & Nepal, S.R. (2015). Financial literacy in Nepal: A Survey Analysis from College Students, Conference Paper, 2nd International Conference on Economics and Finance 26-28.
- Turhan Kaymak & Eralp Bektas, 2017. Corporate Social Responsibility and Governance: Information Disclosure in Multinational Corporations. *Corporate Social Responsibility and Environmental Management*, John Wiley & Sons, 24(6), 555-569.
- Thurik, A.R., Carree, M.A., Van Stel, A. & Audretsch, D.B. (2008). Does self-employment reduce unemployment?. *Journal of Business Venturing*, 23(6), 673-686.

- Tuffour, J. K., & Martey, E. (2019). The success of the global business leader: The expatriate perspective in Ghana. *Journal of Applied Business and Economics*, 21(9), 75–85.
- Tuffour, Amoaka & Amartey. (2020). Assessing the Effect of Finacia Literacy Among Managers on the Performance of Small-Scale Enterprises. *Global Business Review*, 1-18.
- Upward, Antony, & Peter Jones. (2016). An Ontology for Strongly Sustainable Business Models, *Organization & Environment*, 29 (1), 97–123. doi:10.1177/1086026615592933.
- Van Rooij, M., Lusardi, A. & Alessie, R. (2009). Finacia Literacy and retirement planning in the Netherlands. DNB Working Paper No. 231,1-38.
- Waddock, S.A., & Graves, S.S. (1997). The corporate social performance. *Strategic Management Journal*, 8, 303–319.
- Wang, Mei, Keller, Carmen & Siegrist, Michael (2011). The less you know, the more you are afraid of-A survey on risk perceptions of investment products, *Journal of Behavioral Finance*, 12(1), 9-19.
- Wells, P. E. (2013). *Business Models for Sustainability*. Cheltenham: Edward Elgar.
- Wernerfelt, B. (1984). A resource-based view of the firm. *Strategic Management Journal*, 5(2), 171-180.
- Wiklund, J; Patzert, H and Shepherd, A.D. (2009). Building an Integrative Model of Small Business growth. *Small Business economics*, 32, 351-374.
- Wilson, N.C. & Stokes, D. (2005). Managing creativity and innovation. *Journal of Small Business and Enterprise Development*, 12(3), 366-378.
- Wise, S. (2013). The Impact of Financial literacy on New Venture Survival. *International Journal of Business and Management*, 8(23), 30–39. <https://doi.org/10.5539/ijbm.v8n23p30>
- Ullmann, A. (1985). Data in search of a theory: A critical examination of the relationships among social performance, social disclosure, and economic performance of US firms. *Acad. Manag. Rev.* 10, 540–557.
- Yin, Z.C., Song, Q.Y., Wu, Y. & Peng, C.Y. (2015). Financial literacy, entrepreneurial decision and entrepreneurial motivation. *Management World*, 256(1), 87-98.
- Ying, G., Wang, L., Miao, W., & Zhang, X. (2019). The mediating role of environmental innovation on knowledge acquisition and corporate performance relationship: A study of SMEs in China. *Sustainability*, 11(8), 2315.
- Yu, K.M., Wu, A.M., Chan, W.S., & Chou, K.L. (2015). Gender differences in financial literacy among Hong Kong workers. *Educational Gerontology*, 41(4), 315-326.
- Zeynep, T. (2015). Financial Education for Children and youth. *Handbook of Research on Behavioral Finance and Investment Strategies*, 24
- Zuhair, S., Wickremasinghe, G., & Natoli, R. (2015). Migrants and self-reported financial literacy: Insights from a case study of newly arrived CALD migrants. *International Journal of Social Economics*, 42, 368–386.